



# **A review of the use of spaced piles to stabilise embankment and cutting slopes**

**Prepared for Quality Services (Civil Engineering),  
Highways Agency**

D R Carder and J Temporal

First Published 2000  
ISSN 0968-4107  
**Copyright Transport Research Laboratory 2000.**

This report has been produced by the Transport Research Laboratory, under/as part of a Contract placed by the Highways Agency. Any views expressed are not necessarily those of the Agency.

TRL is committed to optimising energy efficiency, reducing waste and promoting recycling and re-use. In support of these environmental goals, this report has been printed on recycled paper, comprising 100% post-consumer waste, manufactured using a TCF (totally chlorine free) process.

The Transport Research Laboratory and TRL are trading names of TRL Limited, a member of the Transport Research Foundation Group of Companies  
TRL Limited. Registered in England, Number 3142272  
Registered Offices: Old Wokingham Road, Crowthorne, Berkshire, RG45 6AU.

# CONTENTS

	Page
<b>Executive Summary</b>	1
<b>1 Introduction</b>	3
<b>2 Case histories</b>	3
2.1 Previous reviews	3
2.2 Gipsy Hill, London	4
2.3 Huy, Belgium	4
2.4 Germany	5
2.5 Japan	7
2.6 Single instrumented piles	7
2.7 Micro- and mini- piles	11
2.8 Summary	13
<b>3 Design approaches used in other construction techniques where soil flow and arching occur</b>	13
3.1 Piled foundations	13
3.2 Dowelling techniques for soil slopes (lime piles, soil nails)	14
3.3 Spill-through abutments	14
3.4 Soil arching (buried structures, silos)	15
<b>4 Current methods for the design of spaced piles to stabilise slopes</b>	15
4.1 Spacing and diameter of piles	15
4.2 Lateral resistance supplied by the piles	19
4.3 Penetration and location of the piles	19
4.4 Overall stability	21
<b>5 Summary</b>	22
<b>6 Acknowledgements</b>	22
<b>7 References</b>	22
<b>Appendix A: The stabilisation of an existing railway embankment at Kitson Wood using large diameter pin-piles</b>	26
<b>Appendix B: Widening of the M25 between Junctions 8 and 10</b>	27
<b>Abstract</b>	29
<b>Related publications</b>	29



## Executive Summary

---

With an integrated transport policy there is likely to be a need to extend highway corridors within existing boundaries to provide extra space for bus/cycle lanes and other modes of transport. In widening situations there is an increasing demand for embankment and cutting slopes to be steepened, so reducing the landtake and associated costs and delays to construction. In many cases the additional lateral loading then developed near the toe of the embankment or cutting can be accommodated by installation of a single row of piles at intervals along the slope.

It is likely that the same technique can be used for the permanent and cost effective reinstatement and repair of unstable or failed slopes. Many motorway slopes, which are prone to shallow failures, are now reaching a critical age for deep seated failure to occur. In addition, prolonged delays in dealing with shallow failures may lead to the formation of deeper slips.

Currently there is little design guidance on the use of a single row of piles to stabilise slopes. This report comprises a review of the currently available literature relevant to the use of piles to stabilise embankment and cutting slopes. The report is divided into three main sections, these are:

- a review of instrumented case histories;
- a review of other construction techniques where soil flow and arching occur;
- a review of current design methods for the used of spaced piles.

In the report, particular emphasis is placed on the influence of pile spacing upon the performance of the stabilised slope.



## 1 Introduction

With an integrated transport policy there is likely to be a need to extend highway corridors within existing boundaries to provide extra space for bus/cycle lanes and other modes of transport. In widening situations there is an increasing demand for embankment and cutting slopes to be steepened, so reducing the landtake and associated costs and delays to construction. In many cases the additional lateral loading then developed near the toe of the embankment or cutting can be accommodated by installation of a single row of piles at intervals along the slope. It is likely that the same technique can be used for the permanent and cost effective reinstatement and repair of unstable or failed slopes. Geotechnical Consulting Group (1993) has predicted that many motorway slopes, which are prone to shallow failures (Perry, 1989), are now reaching a critical age for deep seated failure to occur. In addition, prolonged delays in dealing with shallow failures may lead to the formation of deeper slips.

Determination of pile diameter, spacing, penetration depth and location on the slope is however a complex soil-structure interaction problem on which there is currently little design guidance. A careful balance will need to be struck between maximising the arching effect between piles to utilise the strength of the soil and minimising soil flow between the piles that could lead to progressive failure.

This report comprises a review of the currently available literature relevant to the use of spaced piles to stabilise embankment and cutting slopes. The report is divided into three main sections, these are:

- a review of instrumented case histories;
- a review of other construction techniques where soil flow and arching occur;
- a review of current design methods for the used of spaced piles.

In the report, particular emphasis is placed on the influence of pile spacing upon the performance of the stabilised slope.

## 2 Case histories

Many attempts to develop suitable design methods for piles used to stabilise slopes have been made (see Sections 3 and 4). However only a limited number of case histories have been published, where slopes have been stabilised using bored piles. These are briefly reviewed below.

### 2.1 Previous reviews

Blight (1983), in reviewing early applications of piles to stabilise slopes, reports that Fukuoka (1977) cites examples of their use to stabilise landslides in Japan for over a century. Similarly, Wang and Yen (1974) report that large diameter piles have been used in California, again for landslide stabilisation. In a final case history reviewed by Blight (1983), Sommer (1977) reports on the installation of 3m diameter reinforced concrete piles to stabilise a road embankment which had slipped about 300mm down a shallow slope in the previous 20 months: details are shown in Figure 1. The piles were installed at 9m centres through the sliding mass of disturbed clay and penetrated up to 5m into the underlying firm clay. Overall pile lengths were between 15 and 20m. From back analysis, the residual angle of shearing resistance on the failure plane was between 8 and 9°, and the undrained shear strength of the stable clay was approximately double that of the sliding mass. The design was based on Brinch Hansen (1961), with the target of increasing the factor of safety of the slope from unity to 1.1. The pile reinforcement was designed so that the soil would fail by flow, before the pile failed. Monitoring of the slope showed that movements had practically ceased by one year after installation. However, pressures measured against passive sections of the piles were about  $0.5c_u$ , whilst the pressures measured against the active section were about  $2c_u$ . These values are lower than the bearing capacity factors commonly assumed in design, which tend to be in the range from 4 to 8 (see Section 2.2), suggesting that the design was rather conservative and that the absence of movement after a year is not surprising.

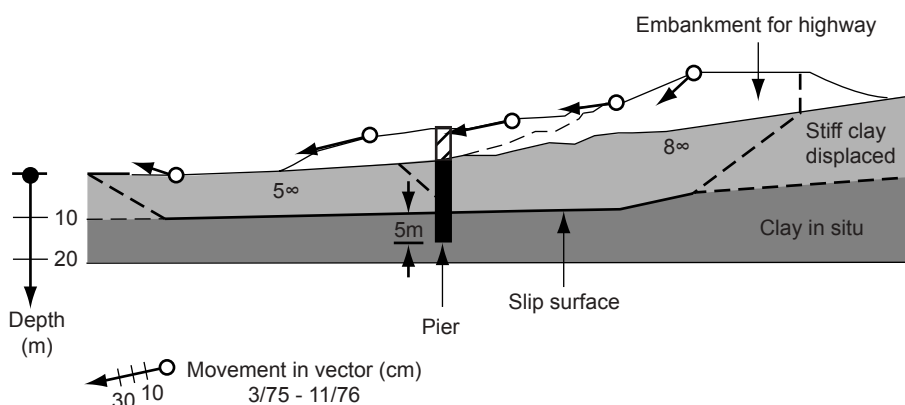

**Figure 1** Cross-section showing the stabilisation works (After Sommer, 1977)  
(By courtesy of the Japanese Association for Steel Pipe Piles)

## 2.2 Gipsy Hill, London

Allison et al (1991) describe the use of three rows of bored concrete piles to stabilise a large slip at Gipsy Hill, South London. A cross section of the failed area is shown in Figure 2. The slip was some 30m wide by 40m front to back and was probably triggered by partially removing an old retaining wall at the toe of the slope. The slip appeared to have occurred on a pre-existing shear plane between 4 and 5m deep with an average angle of 9°. This was coincident with the interface between the relatively intact London Clay and the overlying colluvium and roughly parallel to the original ground surface. Back analysis of the slip surface suggested that the effective shear strength parameters were  $\phi' = 16.1^\circ$  and  $c' = 0$ .

Vertical bored piles were chosen to minimise both material costs and the time required for installation. The piles were 600mm diameter and 10m long with steel 'I' beam reinforcement. Each of the upper two rows contained 8 piles whilst the bottom row consisted of 14 piles. The pile installation was designed using the method proposed by Viggiani (1981) in which the load transfer characteristics of the soil are described in terms of bearing capacity factors and undrained shear strengths assigned to both the moving and stable soil. Low values indicate that soil is flowing past the piles and hence low loads are likely to act on the piles: high values suggest less flow with consequently higher loads. As recommended by Viggiani, bearing capacity factors of 4 and 8 were assigned to the moving and stable soils respectively. Lower and upper bound values of undrained shear strength of 10 and 20kN/m<sup>2</sup> were adopted for the moving soil mass and 20 and 40kN/m<sup>2</sup> were adopted for the stable material.

The instrumentation installed to monitor the slope consisted of piezometers in the ground and inclinometer

tubes in some of the piles. The inclinometer readings showed that the pile deformations stabilised before the subsequent construction of counterfort drains took place with minimal movement occurring after that stage. The piles in the top row underwent the greatest deformation with a maximum lateral movement down the slope of 37mm: movements of the middle and bottom row were about 14 to 15mm. Figure 3 shows the variation of displacement with time for five of the inclinometer tubes. From the analysis of the inclinometer and piezometer data, the following conclusions were reached:

- The maximum load generated in a pile by the soil was some 40% of the value at which shear failure of the soil would be expected to occur, under the most unfavourable groundwater conditions.
- The maximum bending moment in the upper row of piles was approximately 45% of the ultimate capacity and about 20% of ultimate in the lower rows.
- The piles were uniformly loaded over a 6m cantilever length, the maximum lateral load being about one third of the actual load capacity.
- Although the piles were designed to provide a factor of safety of 1.1 under saturated conditions, counterfort drains were also installed. These were designed to increase the factor of safety to 1.35, but back analysis suggests they increase it to about 1.45.

## 2.3 Huy, Belgium

The use of reinforced bored piles to stabilise a slope in schists at Huy in Belgium was described by De Beer and Wallays (1970). In this case, a railway built in about 1900 in cutting in an urban area needed to be widened. This was attempted by cutting back the existing slope in badly

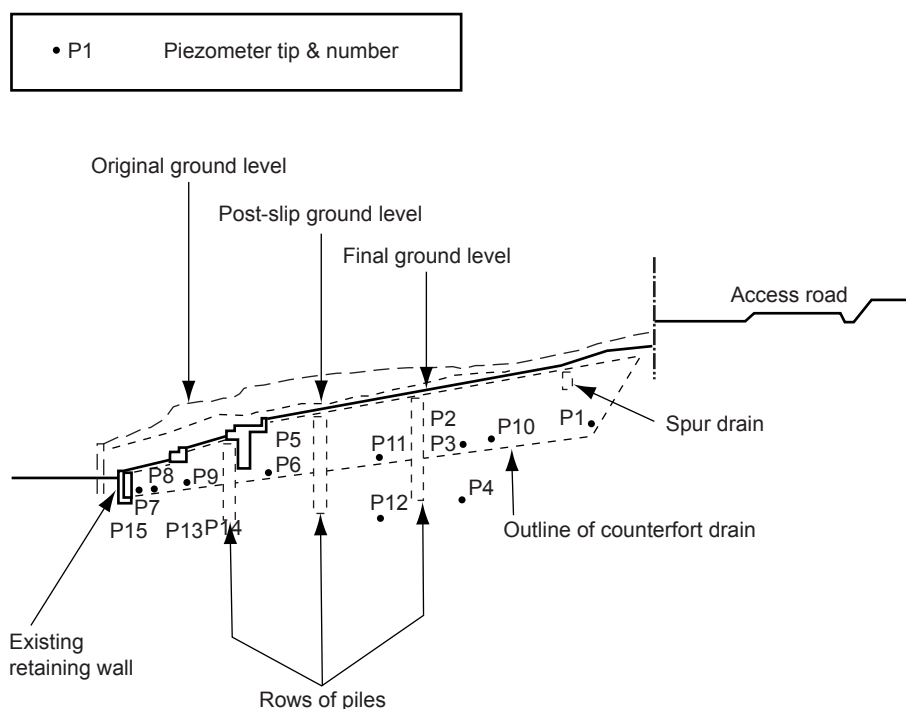

**Figure 2** Cross-section through the site at Gipsy Hill (After Allison et al, 1991)  
(By courtesy of the authors)

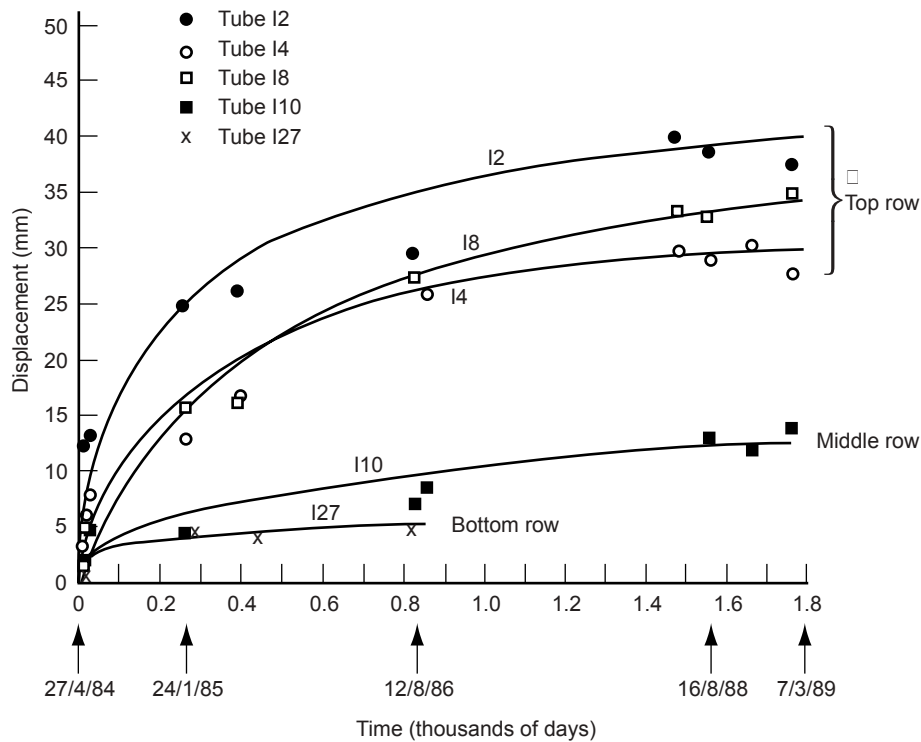

**Figure 3** Pile head displacements at Gipsy Hill (After Allison et al, 1991)  
(By courtesy of the authors)

crushed schist, with a high water table, at the same slope of 1 vertical to 2.1 horizontal as the original cutting. This induced a succession of slips, which were thought to be along old slip planes induced by the original excavation. The slope was stabilised using two rows of anchor piles with diameters of 1070 and 1280mm in the lower row and 1500mm in the upper row. The mean spacing between pile centres in each row was 2m, the piles in the upper row being 20m long and in the lower row 9.9m long. All the piles were reinforced with steel 'I' beams. Figure 4 shows a plan view of the slope and Figure 5 shows a cross section and the location of the anchor piles.

Inclinometers were installed and the positions of the slip surfaces were deduced from the zones of maximum movement in the tubes and the position of fissures at the surface. Piezometers were also installed and the shape of the water table deduced from them together with the water levels in boreholes. Calculation of the characteristics of the piles was carried out in three stages:

- determination from the slip surfaces of the shear resistance to be provided by the piles;
- estimation of the soil pressures on the piles;
- calculation of the embedment length and maximum bending moment.

Values of peak and residual shear strength parameters were obtained from laboratory tests. Peak values were  $\phi'=25^\circ$  and  $c'=80$  to  $120\text{kN/m}^2$ , with residual values of  $\phi'=14.5^\circ$  and  $c'=0$ .

Design strengths for the piles were determined in three ways, firstly using the formulae derived by Brinch Hansen (1961), in which the piles are assumed to have a sufficient separation to diameter ratio to ensure no interaction

between adjacent piles. The second method assumes the piles to be so close together that they can be treated as a continuous wall, whilst the third method, developed by De Beer, assumes the rupture surface for the case of passive pressures against the pile has the shape given by Jaky (1948). For design, values of  $\phi'=14^\circ$  and  $c'=20\text{kN/m}^2$  were adopted for the moving material: values of  $\phi'=24^\circ$  and  $c'=60\text{kN/m}^2$  were adopted for the stable material. Unfortunately the paper does not give any details of construction, nor of the performance of the slope after stabilisation.

## 2.4 Germany

Gudehus and Schwarz (1985) modelled the dowels used to stabilise a slowly creeping slope as if they behaved as elastic beams. The slope itself was treated as a solid body sliding on an inclined plane. Typical creep values of the slopes being modelled ranged from 0.1 to 50mm per month. These slopes generally consisted of nearly saturated stiff clay to depths of 5 to 15m or deeper. In the thin transition zone between the moving and stable ground, the water content was usually higher than in the surrounding soil. The following case studies of the use of dowels are described.

Case A was an 8m high motorway embankment at Dautenheim. The embankment was constructed on a slope of  $5^\circ$ . After several years significant creep movements began. Inclinometers were installed and the location of the sliding surface was found to be in a layer of stiff Tertiary clay, with an undrained shear strength  $c_u$  of  $150\text{kN/m}^2$  and a viscosity index  $I_v=0.03$ . (This index, which was developed at Karlsruhe University, relates shear force to creep velocity. It is determined from modified triaxial tests and has values

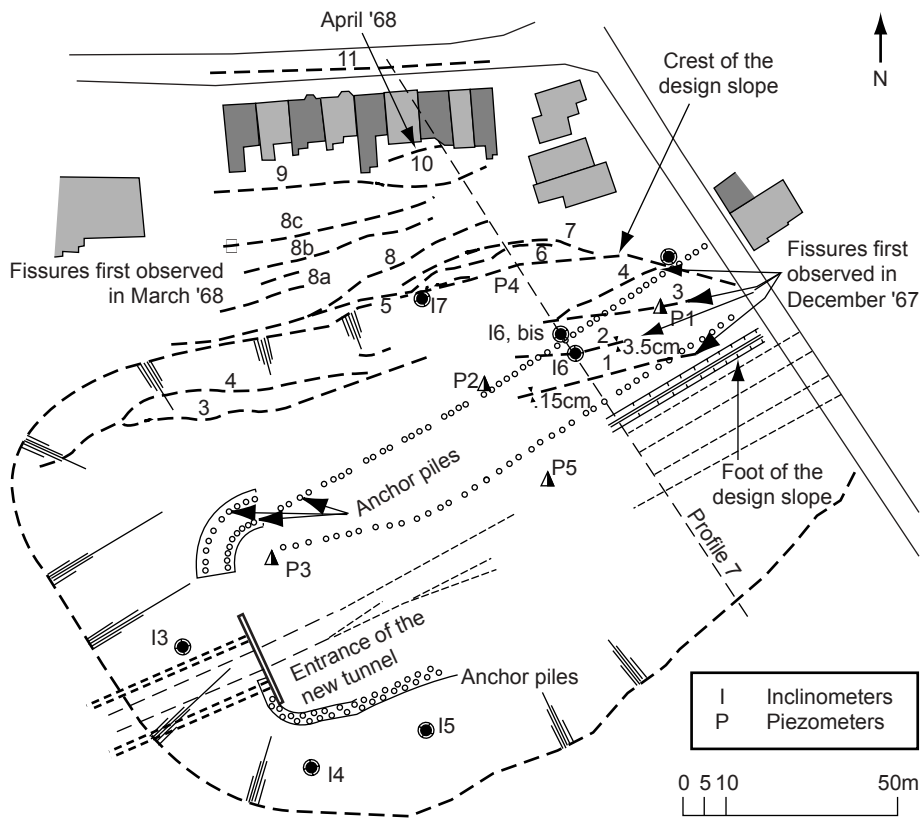

**Figure 4** Plan of the site at Huy, Belgium (After De Beer and Wallays, 1970)  
*(Courtesy, Publishers)*

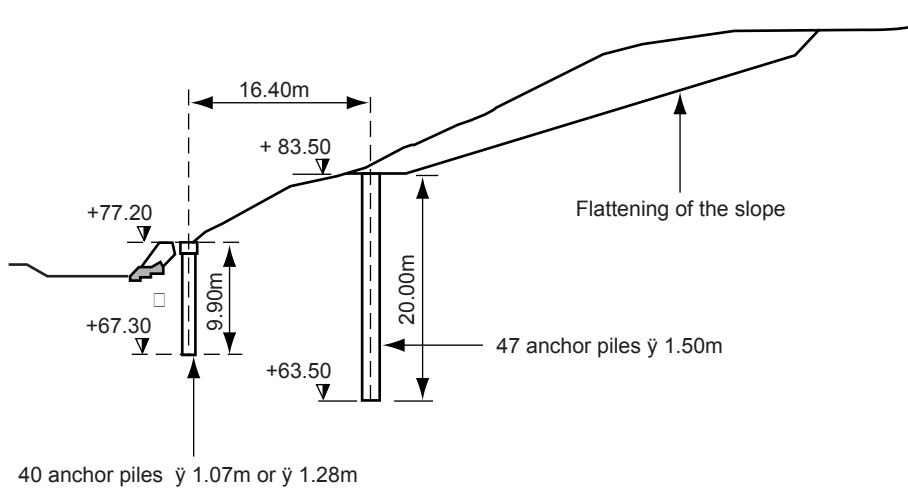

**Figure 5** Cross-section of the site at Huy, showing pile locations (After De Beer and Wallays, 1970)  
*(Courtesy, Publishers)*

in the range 0.01 to 0.06.) Figure 6 shows a section through the site. The landslide was stabilised using two rows of 1.5m diameter dowels whose distribution is also shown in Figure 6. The creep rate was reduced to an undetectable level from its initial rate of 1 to 1.5mm per day.

Case B was a cutting slope in stiff fissured Jurassic clay constructed for a railway some 100 years ago at Geislingen. The clay had an undrained shear strength  $c_u$  of 150kN/m<sup>2</sup> and a viscosity index  $I_v=0.035$ . The slope had exhibited creep movements since its construction. Inclometers were installed and the failure mechanism shown in Figure 7 identified. The slope was stabilised using two rows of reinforced concrete dowels with diameters of 400mm. Within the 25 week period in which the slope was subsequently monitored, the creep rate was reduced from 4.7mm/month to 1.3mm/month. Further details of this case study are given in Schwarz (1984).

Case C was another part of the same slope as Case B at Geislingen. In this test, the slope was stabilised with 'grouted' dowels. Steel tubes of 1.5 and 2 feet diameter were installed in pre-bored holes and the holes grouted up with a mix of cement and silica (sic). Three different dowel distribution densities were tested, together with an un-dowelled control section, as shown in Figure 8. In the text, Gudehus and Schwarz (1985) use the description 'small dowels' for this test and Figure 8 suggests that 1.5 and 2 inch diameter pipes were used, rather than 1.5 and 2 feet diameter tubes. Although there is some doubt, it appears likely that the 'small dowels' were in fact grouted soil nails. The paper reports that each of the three stabilised sections reduced the creep movements in the short term, but increasing lateral loads on the dowels in the longer term caused them to fail.

## 2.5 Japan

Ito and Matsui (1975) compared the design methods they had developed based on plastic deformation and plastic flow mechanisms to estimate the lateral force acting on a row of piles with measured values obtained from piles used to stabilise slowly moving landslides at Katamachi, Higashitono, and Kamiyama in Japan. The landslides consisted of clay layers several metres thick mixed with pieces of mudstone. At Katamachi, hollow reinforced concrete piles 300mm in diameter with a wall thickness of 60mm were used, whilst those at the other two locations were steel pipe piles 318.5mm in diameter with a wall thickness of 6.9mm. The piles were arranged in a zig-zag pattern in two rows 2m apart, the pile interval being 4m. Strain gauges were attached to the piles and the lateral forces calculated from the measured strains in the piles.

Figure 9 shows the comparisons between theoretical and observed values for five piles. The analysis based on plastic deformation assumes a Mohr-Coulomb yield criterion, whereas the plastic flow model is based on viscoplasticity. The former model is therefore likely to be more appropriate in harder materials, whilst the latter is likely to be more appropriate in softer deposits. The results in Figure 9 show that both theoretical models agree reasonable well with the observations, although the plastic deformation model is slightly better. The model by Hennes consistently underpredicts the observed loads, whilst that

of the PWRI consistently overestimates them. The limitations of the Hennes and PWRI models are discussed in the paper, but references to them are not provided.

## 2.6 Single instrumented piles

Chen and Poulos (1997) developed a theoretical procedure for analysing the lateral response of vertical piles to lateral soil movements using boundary element analysis. The model was then applied to their earlier model tests on piles in sand: for both single piles and pile groups, the model significantly overestimated the measured bending moments. Chen and Poulos (1997) also described several field trials involving single instrumented piles. Of these, Cases 3, 4 and 5 were installed in unstable slopes. Case 3 was from a paper by Esu and D'Elia (1974), in which they described a field test where a reinforced concrete pile, 30m long and 790mm diameter with a bending stiffness of 360MNm<sup>2</sup> was installed in a slope consisting mainly of clay in which the upper 7.5m layer was undergoing lateral movement. The pile was instrumented with pressure cells at three levels on both up and down-slope sides of the pile. An inclinometer was also installed in the pile. Over a monitoring period of 8 months the loads on the pile steadily increased until a plastic hinge developed at about 11m below ground level. Figure 10 shows the measured bending moment, shear force and pile deflections together with predicted values. The predicted values are remarkably close to those measured, but this is largely due to the fact that the soil parameters used in the analysis were chosen to match the theoretical and observed bending moment profiles.

Case 4 from Chen and Poulos (1997) concerns a trial by Carruba et al (1989). In this test, an instrumented reinforced concrete pile 22m long and 1.2m diameter was installed to stabilise a moving slope. The pile was instrumented with pressure cells and an inclinometer. The slip surface was found to be 9.5m below ground level. The undrained shear strength of both the stable and moving layer was found to be about 30kN/m<sup>2</sup>. Over a period of 5 months the forces acting on the pile increased until a plastic hinge developed at 12.5m below ground. The measured bending moments, shear force and distributed load are shown in Figure 10. Again, the same caveats apply to the agreement between predicted and measured values.

In Case 5 from Chen and Poulos (1997), Kalteziotis et al (1993) reported a trial where two rows of piles were used to stabilise an unstable slope on which a semi-bridge structure had been built. The soil conditions were mainly lacustrine deposits over 100m thick, overlying bedrock of Triassic marl. Three steel pipe piles instrumented with strain gauges were included to study the lateral reaction mechanism in a landslide. All the piles had a length of 12m, a diameter of 1.03m, a wall thickness of 18mm, and a flexural stiffness of 1540MNm<sup>2</sup>. The centre to centre spacing of the piles was 2.5m. The measured and predicted pile responses are given in Figure 10. Based on the results of pressuremeter testing reported by Kalteziotis et al (1993), the limiting soil pressure was taken to be 0.9 and 3.2MN/m<sup>2</sup> for the moving and stable layers respectively, whilst the Young's Modulus values were taken to be 15 and 70MN/m<sup>2</sup>. As in the previous analyses by Chen and Poulos (1997), the same caveats apply to the agreement between predicted and measured values.

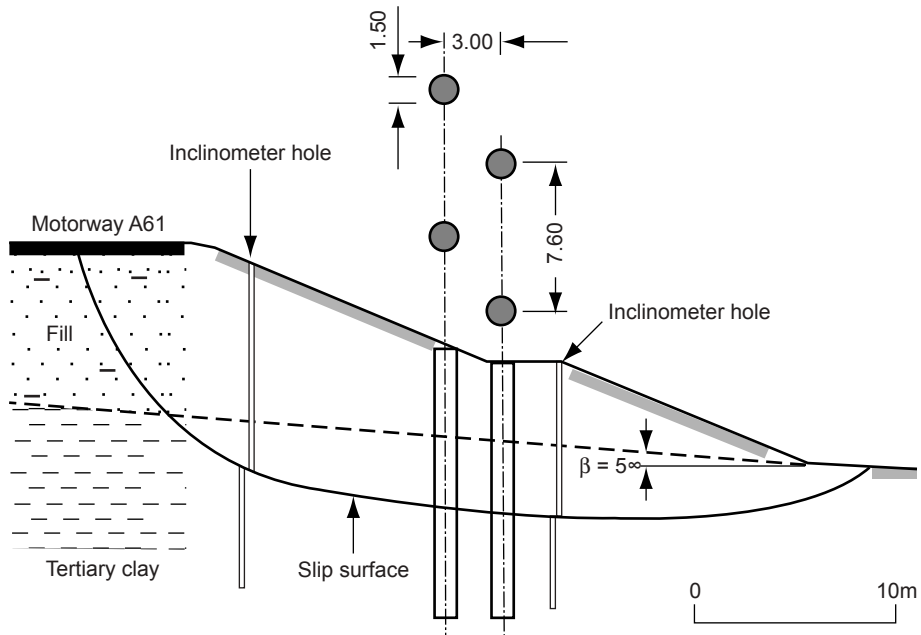

**Figure 6** Dowelling at Dautenheim (After Gudehus and Schwarz, 1985)  
*(By courtesy of A A Balkema)*

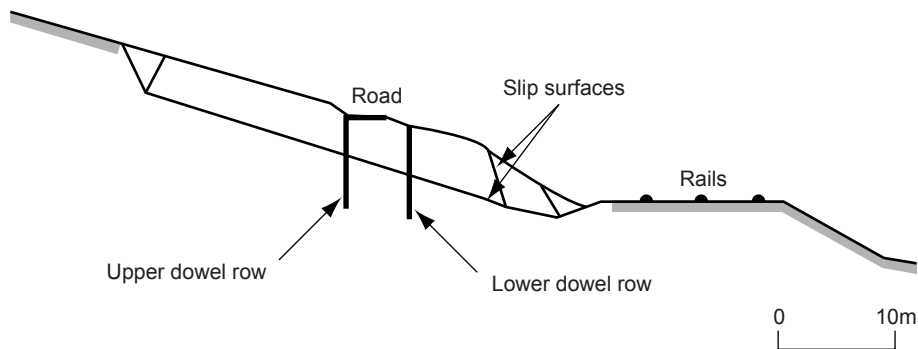

**Figure 7** Cross-section of the test field Geislingen I (After Gudehus and Schwarz, 1985)  
*(By courtesy of A A Balkema)*

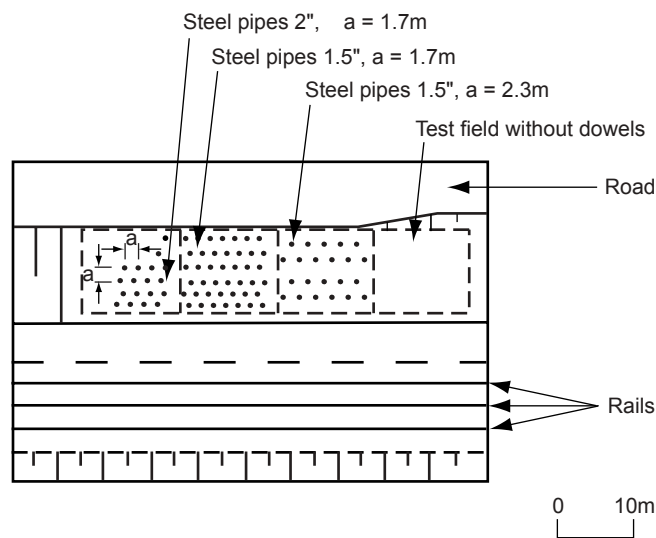

**Figure 8** Plan of the test field Geislingen II (After Gudehus and Schwarz, 1985)  
*(By courtesy of A A Balkema)*

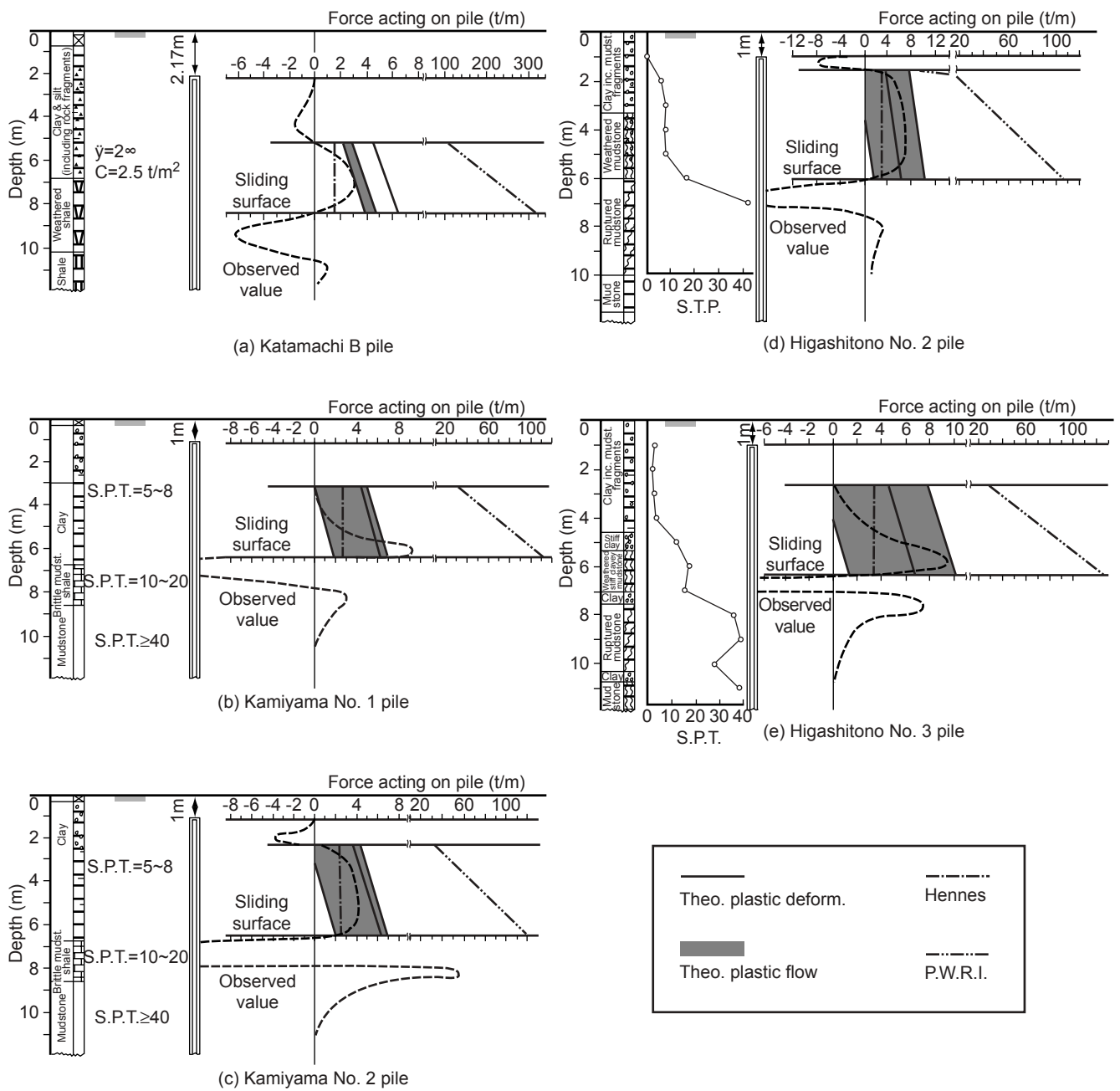

**Figure 9** Theoretical and observed values of lateral force acting on stabilising piles (After Ito and Matsui, 1975)  
*(By courtesy of the authors)*

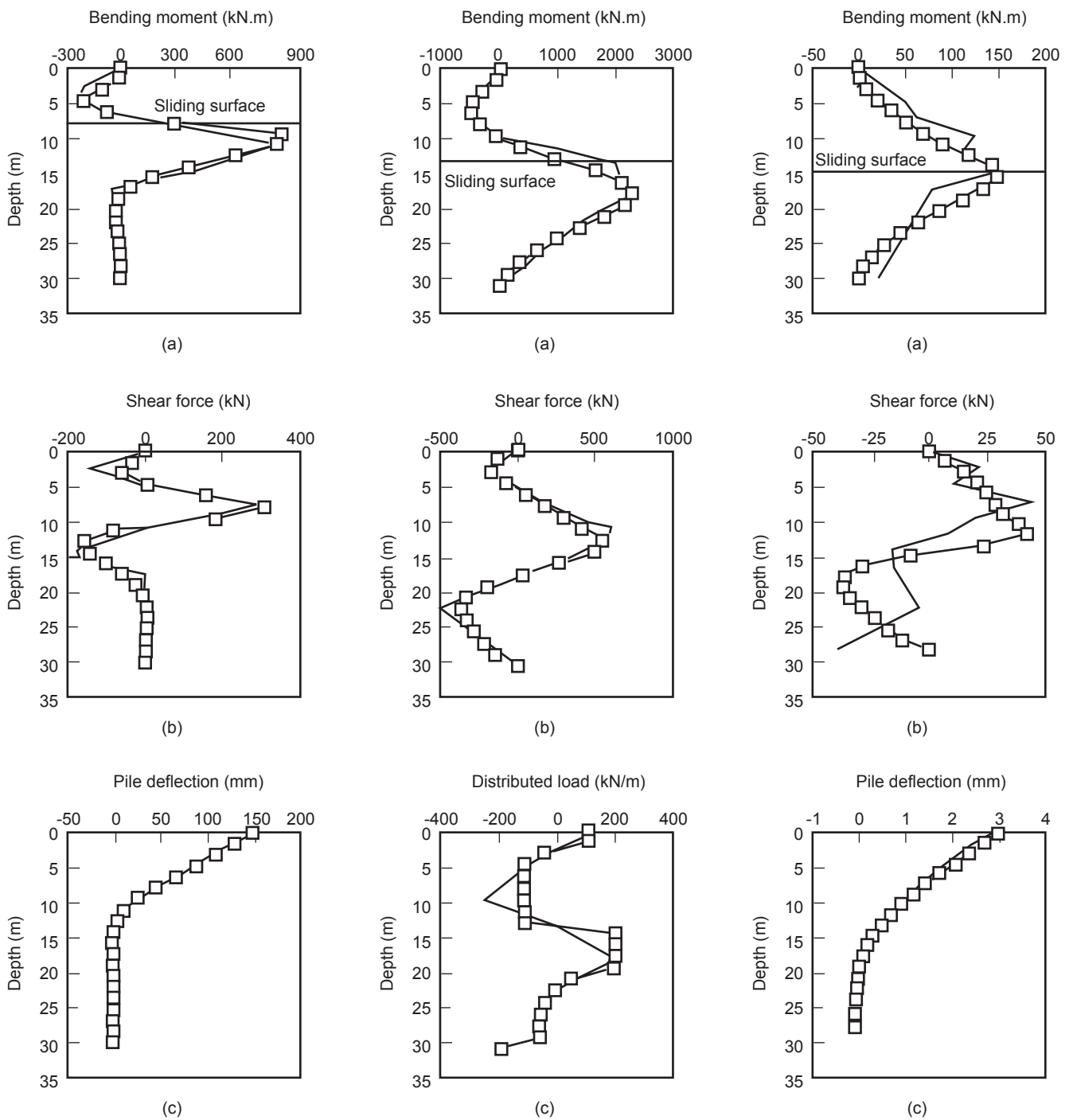

Case 3: Esu and D'Elia, 1974

Case 4: Carruba et al, 1989

Case 5: Kalteziotis et al, 1993



**Figure 10** Predicted and measured pile response (After Chen and Poulos, 1997)  
(By courtesy of ASCE)

## 2.7 Micro- and mini- piles

A news item in Engineering News Record (1977) describes the use of the Fondedile pali-radice system which was installed to stabilise a 98m long section of embankment. The system consists of 721 cast in place concrete piles, each 125mm in diameter with a single steel reinforcing rod. The piles were drilled at various angles from 0° to 19° to the vertical forming a web-like structure. The tops of the piles were held together by a 760mm thick capping beam 98m long by 2.4m wide. The completed installation was being monitored by the US Army Corps of Engineers to determine stress changes in selected piles. Finite element and centrifuge studies were also being undertaken, but references to the subsequent work have not been found.

Cantoni et al (1989) describe a design method for reticulated micropile structures adopted to stabilise slope failures. The design method gives simple criteria for setting out the spacing and number of rows of micropiles. Its use in stabilising a slope along the Milan-Rome motorway in the mountains near Florence is described in detail. A plan and section of the slide and the layout of the stabilisation works are shown in Figures 11 and 12. The area subject to sliding was identified by means of ground and aerial surveys together with inclinometers and piezometers installed in the ground. The soil profile comprised two formations: a detrital unstable upper layer 13m to 16m thick made up of sandy silt with gravel inclusions and bedrock consisting of a flysch formation, alternate marl and sandstone. The properties of both layers are given in Table 1. The failure surface, with a maximum depth of 15m, coincides with the interface between the sandy silt layer and the bedrock.

**Table 1 Geotechnical parameters for the site near Florence (after Cantoni et al, 1989)**

### A Upper formation

#### Grain size distribution

Gravel: 44%  
Sand: 20%  
Silt: 24%  
Clay: 12%

#### Index properties

Liquid limit (LL) = 39.8%  
Plastic limit (PL) = 16.5%  
Natural moisture content = 17.1%  
Consistency index ( $I_c$ ) = 0.93

Unit weight ( $\gamma$ ) = 20 to 21 kN/m<sup>3</sup>

Residual angle of shearing resistance ( $\phi_r$ ) = 19°

### B Bedrock

Unconfined compressive strength ( $q_u$ ) = 8 to 10 MN/m<sup>2</sup>  
Rock quality designation (RQD) = 60 to 70%

The solution chosen for the stabilisation consisted of four connecting beam structures on reticulated micropiles on the down-slope side of the motorway. Each of these structures was 12.5m long with 14 micropiles per linear metre. Each micropile was 200mm in diameter and arranged in equilateral triangular arrays at 500mm centres: they extended at least 5m into the bedrock, giving an

overall micropile length of 20m. The reinforced concrete connecting beams were anchored into the bedrock by 40m long, 90t active anchors at 2m centres.

The method was chosen for the following reasons:

- to avoid working on the motorway and hence avoid traffic disruption;
- to obviate the need for heavy equipment to work on the steep slope;
- to minimise changes to the percolating water regime in the slope;
- to avoid large borehole diameters, because of occasional boulders in the upper layer and the need to penetrate the bedrock.

The solution was assumed to produce soil blocks reinforced with micropiles and nailed to the bedrock, with the connecting beam anchored into the bedrock. In addition, the micropiles were injected with grout at sufficient pressure (500 to 1000kN/m<sup>2</sup>) to improve adhesion between the micropiles and the soil.

The stability of the structure was analysed with respect to the following failure mechanisms:

- a plastic deformation of the soil between adjacent micropiles;
- b sliding of the reinforced soil block on the undisturbed soil;
- c structural failure of the composite cross section of the block.

Mechanism (a) was considered by comparing the horizontal thrust exerted on the structure by the sliding soil mass with the limiting resistance developed by arching between adjacent micropiles using the methods proposed by Ito and Matsui (1975, 1977), which were described in Section 2.5. Mechanism (b) was considered using the thrust determined from seismic conditions as a result of a pseudo-static analysis based on the simplified method of Janbu (1973). Mechanism (c) was analysed by treating the structure as a flexible retaining wall using the method of Matlock and Reese (1960). Although Cantoni et al (1989) describe the design in considerable detail, their paper does not give any details of how the system performed.

Singleton (1996) discusses a number of techniques developed by Keller Foundations to stabilise rail embankments. These include, *inter alia*, a system in which micropiles have been installed close to the crest of embankments to improve their stability. It is claimed that this has advantages over stabilisation near the toe, as it minimises the potential for soil movements under the rail trackbed, rather than retaining the failing material and allowing it to consolidate. It also allows visual intrusion to be minimised as most vegetation can be left in place. In variations of the technique, reinforced concrete capping beams and raked tension piles have also been added. Details of pile diameter, spacings and length used are not given, and details of how the system has performed are not reported.

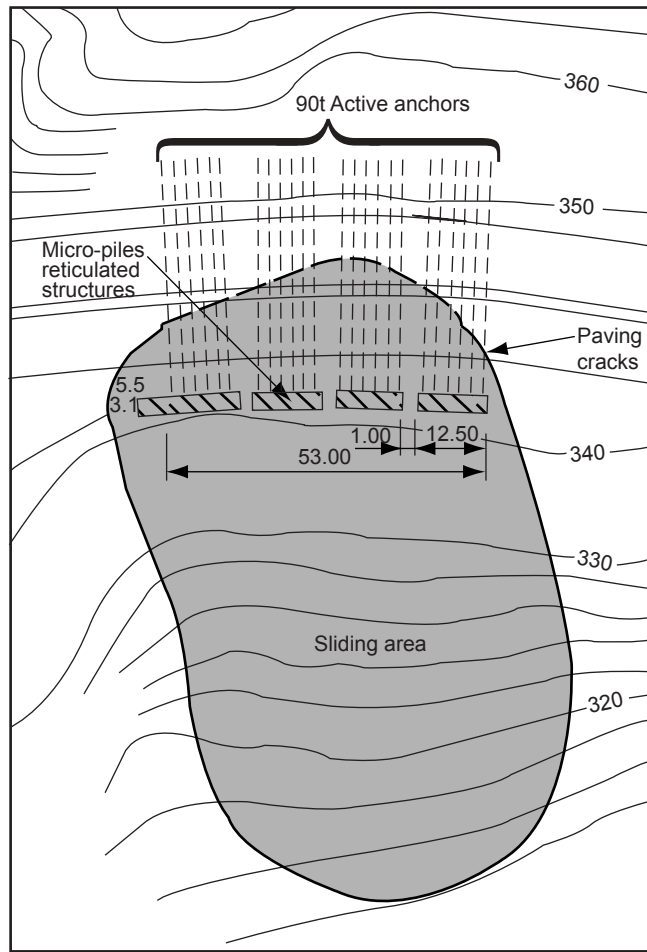

**Figure 11** Plan of the remedial works on the Milan-Rome motorway near Florence (After Cantoni et al, 1989)  
*(By courtesy of Emap Construct)*

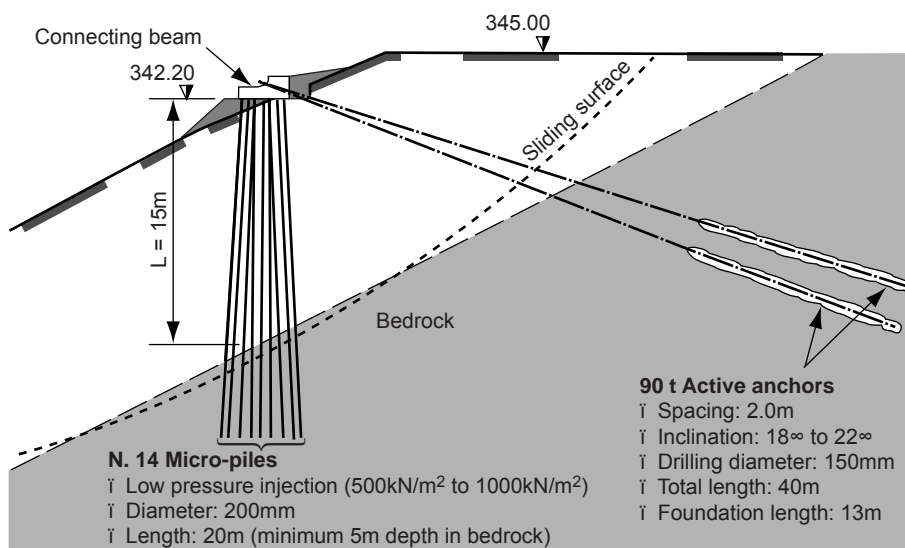

**Figure 12** Typical section through the remedial works on the Milan-Rome motorway near Florence (After Cantoni et al, 1989)  
*(By courtesy of Emap Construct)*

## 2.8 Summary

In addition to the review of published data, two unpublished case histories demonstrating the diversity of construction techniques using spaced bored piles which have been used in the UK are given in Appendix A and B. Appendix A describes the stabilisation of an existing railway embankment at Kitson Wood using two rows of large diameter pin-piles located towards the toe of the slope. The widening of the M25 between junctions 8 and 10 is described in Appendix B and in this case, for site specific reasons, the piles were located close to the backscar of potential slip surfaces to ensure stability of the widening works.

This review shows that, although there is a paucity of reported case histories of the use of spaced piles to stabilise slopes, they appear to have been used widely and with success for some considerable time. The effort that has been devoted to developing design methods (see Sections 3 and 4) suggests that their use may have been more extensive than that indicated by the low volume of case histories reported. Stabilisation of landslides and natural slopes appears to have been more frequent than attempts to stabilise embankments. However, the cases that have been reported suggest that spaced piles may form a useful method of stabilising highway earthworks, provided that realistic design criteria can be developed.

## 3 Design approaches used in other construction techniques where soil flow and arching occur

### 3.1 Piled foundations

The construction of approach embankments to bridges on compressible subsoil can induce lateral loading on the piled foundations which causes bending and shear in the piles. This problem is compounded where the piles pass through a soft layer and are founded within a stiffer substratum. In this case the soft soil attempts to flow between the piles, causing passive lateral thrust on them. This behaviour has analogies with the use of discrete bored piles for stabilising slopes as the design objective is to prevent lateral movement of the soil between the piles.

Various approaches to evaluate the effects of lateral loading on piled foundations have been summarised by Stewart et al (1994) and separated into the following categories:

- i *Empirical methods* – the pile response is estimated in terms of maximum bending moment and pile head deflection on the basis of laboratory and field soils data (Oteo, 1977; Stewart et al, 1994).
- ii *Pressure based methods* – Simplified distributions of lateral pressure acting against the piles are assumed and used to calculate the maximum bending moment in the piles and, in some cases, predict deflections (De Beer and Wallays, 1972; Begemann and De Leeuw, 1972; Springman and Bolton, 1990; Stewart et al, 1994).
- iii *Displacement based methods* – the distribution of lateral soil displacement is input and the resulting pile deflection and bending moment distribution calculated

normally using finite difference techniques (Poulos, 1973; Marche, 1973; Bourges et al, 1980).

- iv *Finite element analyses* – the piles are represented in the mesh and pile bending moments and deflections calculated under the applied loading (Carter, 1982; Springman et al, 1990; Stewart et al, 1994).

One of the more recent and comprehensive computer-based design methods developed by Springman and Bolton (1990) incorporates a pressure based method (ii) within a framework of centrifuge and finite element (iv) calculations. This method is now described in more detail.

When laterally loaded, the idealised response of the pile is for its upper section to cantilever out of the soft-stiff soil interface whilst receiving horizontal thrust from the soft soil, which has a greater lateral deformation than the pile. The lower section is embedded in the stiff substratum and resists the lateral loading from the upper layer. Under working load conditions, the magnitude of this passive pressure is proportional to the differential displacement,  $\delta u_s - \delta u_p$ , between the soil and the pile multiplied by the local shear modulus,  $G$  (Baguelin et al, 1977; Springman and Bolton, 1990). The pressure on a pile of diameter  $d$  is then given by:

$$p = 5.33G(\delta u_s - \delta u_p) / d$$

These profiles of movement and the lateral pressure diagram for the pile are illustrated in Figure 13. Springman and Bolton (1990) suggested that various adaptations of this lateral pressure diagram, which is a function of both shear modulus and differential soil-pile displacement, could be made for several reasons. These include a lower soil stiffness at the top of the soft layer, a reduced effective depth of lateral loading in a deep soft layer, and restraint on the soil from the pile cap which will tend to reduce differential displacement at the top of the soft layer. The modified formula for pressure on the pile developed by these authors included an allowance for the increased shear strain in the region around the pile where the shear modulus may be lower than elsewhere due to pile installation effects. Results from centrifuge model tests and finite element calculations, which indicated that the lateral pressure profile in the soft layer is approximately parabolic, were incorporated in their computer-based method of analysis for groups of piles.

The complexity of the soil/pile interaction is such that design procedures for pile groups have tended to focus on ensuring that pile bending capacity is sufficient for the lateral loading. Simple guidance on the interaction between piles embedded in clays where they are in an infinitely long row is however available and has been reported by Chen and Poulos (1997). If  $f_p$  is a dimensionless factor relating the limiting pile-soil contact pressure for a pile in the row to that of the contact pressure for a single pile, values of  $f_p$  of 1.2, 1.1 and 1.0 were conservatively established for pile spacing/diameter ratios of 3, 4 and greater than 8 respectively. This finding can be compared with that of Stewart (1992) who found from observations of centrifuge model pile group tests that a pile spacing of about 5 times the pile diameter was sufficiently

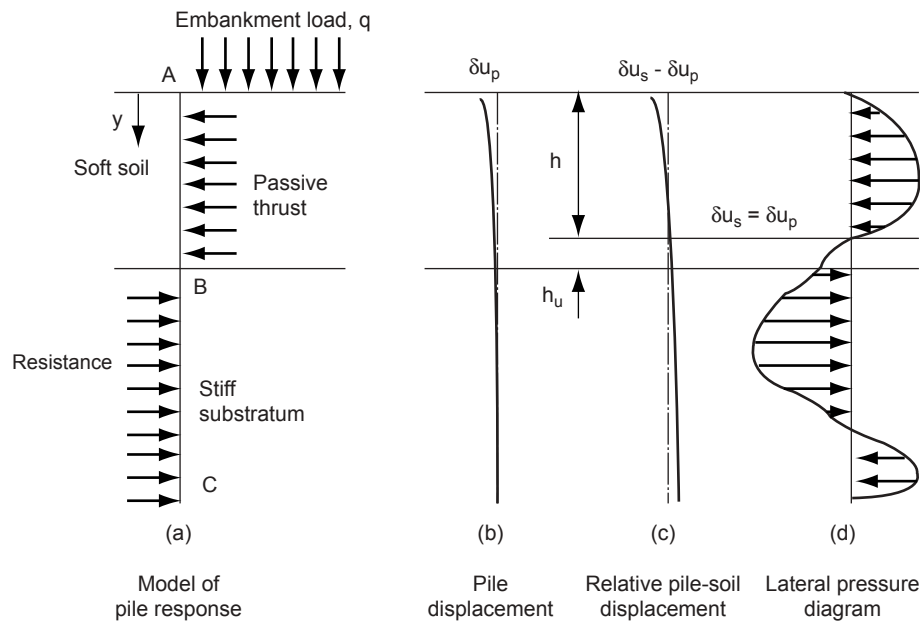

**Figure 13** Profiles of lateral movement and pressure for piled foundation (After Springman and Bolton, 1990)

large to minimise the interaction between adjacent piles. On this basis it can be then argued that in a slope situation, flow of soil between piles is fairly certain at spacings of more than 8 diameters and possibly likely at spacings of more than 5 diameters.

This conclusion for a single row of piles is also consistent with the results from model tests on pile groups reported by Prakash and Saran (1967). They found from load-displacement measurements that the interaction between piles tends to vanish when pile spacing approaches 5 to 6 diameters.

### 3.2 Dowelling techniques for soil slopes (lime piles, soil nails)

In general when using dowelling techniques to stabilise earthworks slopes, no allowance is made for the effects of either soil arching between dowels or flow of soil between them. Design is normally based on identifying the potential slip plane in the slope. This may be a shallow, more-or-less planar, failure confined to the slope or in other cases a deep-seated failure involving both the slope and the underlying stratum. In the design, the depth of the dowels is then such that they cross the potential slip plane with the dowels performing the simple mechanical function of adding shear strength to the soil on the plane.

Dowels can be installed using different construction techniques. The use of small diameter piles where boreholes are backfilled with quicklime or lime-stabilised soil has been reviewed by West and Carder (1997). In some instances the lime-stabilised soil is mixed in place using cement as an additional binder (Swedish Geotechnical Society, 1995; Bachy Limited, 1996). In other cases a steel reinforcing bar has been placed centrally within a small diameter quicklime pile to give additional strength (Oliver, 1995). The use of waterwell screen pipe to line a lime pile has also been reported as advantageous by Brookes et al (1997).

Other forms of construction such as soil nailing and willow poles can also be considered to add some stability to a slope by dowelling action although the main mechanism of their action may be very different. For example, soil nailing relies upon tensile loads being carried by the nail (Johnson and Card, 1998). The main benefit of dowelling using live willow poles lies in their ability to take water in from the slope so improving its stability (Barker, 1999).

These techniques are not discussed in further detail in this report as although arching and flow of soil between small diameter dowels is a mechanism which may occur, it is generally a second order effect and not considered in the design procedures.

### 3.3 Spill-through abutments

The design of the piers of a spill-through bridge abutment is analogous to that of the use of a single row of discrete piles to stabilise a slope in so far as both problems are three dimensional and involve soil arching between adjacent piers and piles respectively. Although spill-through abutments are widely used in the UK and elsewhere, the simplistic design approaches developed many years ago tend still to be employed. These design approaches were summarised by Hambly (1979) and are as follows:

- Lateral earth pressures on the piers are not considered for stable embankments whose slopes are less than 1 in 2. This is on the basis that the abutment neither affects the stability of the embankment nor influences the movement of the embankment. It must be noted that embankment fill in a spill-through abutment situation is normally granular material whereas for example, with a bored pile in a clay slope, lateral earth pressures on the pile may develop at lower slope angles.
- Full active pressures are applied to the upslope side of the pier with no reduction for the downslope resisting pressures following the approach of Chettoe and Adams

(1938). As arching of the soil between the piers will transfer more pressure onto the piers, an allowance of up to 100% is added to these active pressures. Further information on the application of this approach is given by Randolph et al (1985) and the Institution of Structural Engineers (1989) who evaluated this allowance assuming the maximum soil lateral stress behind a pier reduced with distance from the pier according to a 2/3 power law established from centrifuge testing (Ah-Teck, 1983). When this distance exceeded 4d, where d is the diameter or width of the piers, stresses in the ground were at the minimum active pressure. This means that the upper limit of pier spacing to diameter (or width) for the effects of arching in granular soil is 8d. It must be noted that in earlier centrifuge tests, Lee (1982) suggested a maximum ratio of 5d.

- c Provided that the openings between piers were less than twice the pier width, full active pressure is assumed to act over the gross width of the abutment. This assumes that the soil arches perfectly between the piers at small spacings. The restoring force on the downslope side is restricted to no more than the passive pressure calculated with due allowance for the descending slope. This method was proposed by Huntington (1957).
- d Full active pressure is applied over the gross width of the abutment. This approach follows conventional retaining wall design and is overly conservative.

Further developments in the design rules for spill-through abutments have not taken place because it is generally appreciated that the magnitudes of soil stresses against and bending moments in the piers will depend on site specific considerations such as the construction sequence and the seasonal variation of horizontal loading from the bridge deck.

A case history study of the performance of the spill-through abutments for a four span continuous voided slab bridge is well documented by Lindsell and Wickens (1987) and Lindsell et al (1984). Initially the lateral pressures on the back and front faces of the piers were very closely balanced during backfilling around them and approximated to an earth pressure at rest condition. Compaction of the backfill behind the capping beam produced very high lateral stresses against the beam. However, over a four year period, these pressures generally reduced to zero due to thermal movements of the deck.

### 3.4 Soil arching (buried structures, silos)

Soil arching is encountered in a number of engineering problems and involves the transfer of soil pressure from a yielding zone to an adjacent non-yielding support. The classic studies of soil arching involved predicting pressures on a yielding trap door within a structure assuming a condition of shear failure (Terzaghi, 1936 & 1943). A similar approach based on shear plane concepts was adopted by Marston (1930) and Spangler (1950) for calculating pressures on conduits buried in trenches. Associated theories were also investigated by Jenike (1964) for the axially symmetric case of arching which occurs in granular materials in storage bins and silos.

In addition to methods of analysis based on shear failure, elastic theory has been extensively used to predict the behaviour of granular soils. Early approaches on this basis were reported by Finn (1963) and Chelapati (1960).

Although the historical development of soil arching theories outlined above is of interest in providing background information, the geometry and stress conditions existing in a slope situation are completely different and for this reason soil arching over buried conduits and in silos is not discussed in any more detail. Specific theories of arching between discrete piles in a slope situation have been developed and these are particularly pertinent to the design spacing between piles. These theories are dealt with separately in Section 4.1.

## 4 Current methods for the design of spaced piles to stabilise slopes

In general, the current design approaches involve three main stages which are:

- evaluating the restoring shear force needed to achieve the required factor of safety for stability of the slope;
- evaluating the shear force that each pile can provide to resist sliding;
- selecting the diameter, centre to centre spacing, penetration and most suitable location on the slope for the piles.

It does not necessarily follow that these stages need to be considered in the above order as they are inter-related. In many cases, for site specific reasons, details of the pile dimensions and layout may well be established first.

### 4.1 Spacing and diameter of piles

The spacing between and diameter of piles must be designed to maximise the arching of the soil between the piles whilst minimising the flow of soil between them. Various theories have been developed for design purposes based on a combination of elastic and plastic soil behaviour. The more widely used methods are now summarised.

#### *Methods based on rigid-plastic behaviour*

Methods have been developed based both on a yielding layer which is parallel to the slope and on a wedge type failure. These methods are now summarised.

- a The method reported by Wang and Yen (1974) is fairly classical for an infinitely long slope and uses rigid-plastic theory to consider the forces on an element of soil in a yielding layer which is parallel to the slope as shown in Figure 14. As would be anticipated they found more arching occurred as the strength of the soil increased, ie.  $\phi'$  and  $c'$  increased.

For a sandy soil ( $c'=0$ ) and using the nomenclature as defined in Figure 14, Wang and Yen found a critical spacing ( $m_{cr} = B/h$ ) as follows:

$$m_{cr} = \frac{K(K+1) \tan \phi}{\cos i (\tan i - \tan \phi_1)}$$

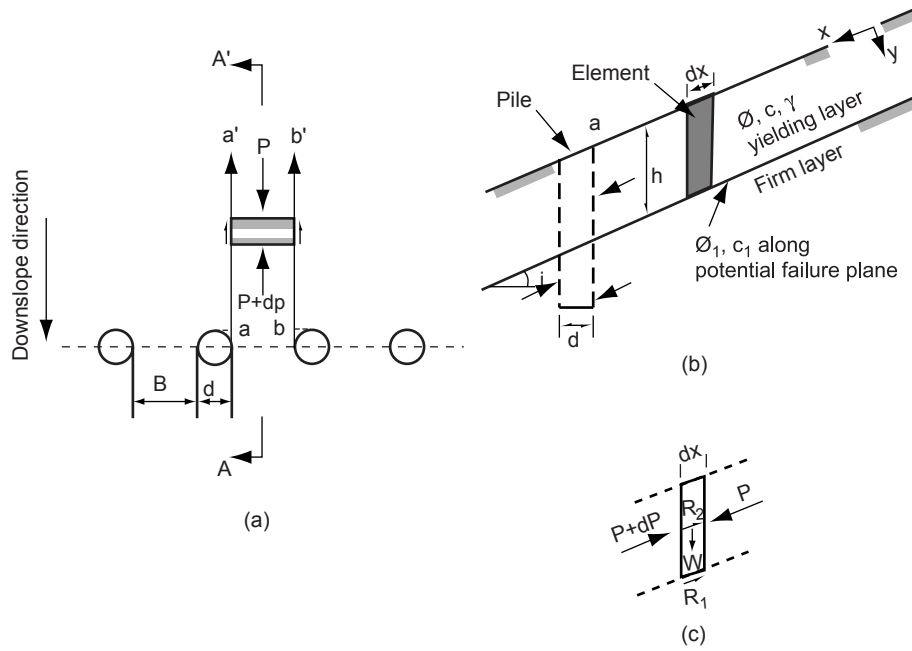

**Figure 14** Plan view of series of piles: (a) on slope; (b) cross-section; (c) generic element (After Wang and Yen, 1974)  
(By courtesy of ASCE)

where  $K$  is the coefficient of earth pressure at rest and assumed to be equal to  $(1 - \sin \phi')$ . At spacings greater than  $m_{cr}$  the piles are not likely to provide any stabilisation. An optimum spacing ( $m_m$ ) was also derived at which arching is likely to be most effective and the variation of critical and optimum spacings with  $\phi'$  is illustrated in Figure 15 for a 1 in 2 slope.

A similar relationship was developed for cohesive soil ( $\phi'=0$ ) and this is as follows:

$$m_{cr} = \frac{2(c/\gamma h)\cos i}{\cos i \sin i - (c/\gamma h)}$$

This equation is plotted in Figure 16 for  $c$  equal to  $c_1$  and a number of slope angles.

It must be noted that the diameter of the piles is not directly involved in the above formula as the arching is assumed to be related to the opening between piles and Wang and Yen assumed that pile size would be sufficiently large to enable the arching mechanism to develop.

- b Typical of the wedge type methods is the approach reported by Day (1999) for drilled piers used to stabilise slopes. Figure 17 shows a planar rupture surface inclined at an angle ( $\alpha$ ) to the horizontal. The factor of safety of the slope can then be defined by considering

restoring and perturbing forces parallel to the rupture surface using the equation:

Factor of safety

$$= \{c' L + (W \cos \alpha - uL) \tan \phi' + P_i\} / W \sin \alpha$$

where  $L$  is the length of the slip surface and  $W$  is the weight of the failure wedge material. For a particular factor of safety, the inclined force on the pier ( $P_i$ ) can then be calculated and the lateral design force ( $P_L$ ) for each pier determined using:

$$P_L = S P_i \cos \alpha$$

where  $S$  is the spacing between pier centres.

#### Methods based on plastic deformation

Ito and Matsui (1975) and Ito et al (1981) considered the state of plastic deformation in the ground just around the piles (Figure 18) assuming it satisfied the Mohr-Coulomb yield criterion. When piles are placed at intervals along the slope they have a preventive effect against plastic deformation. A number of equations and design charts were developed for different soil strengths which enabled the force acting on the pile to be determined. For example the equation for the lateral force ( $p$ ) acting on a pile per unit thickness of layer is as follows:

$$p = cA \left( \frac{1}{N_\phi \tan \phi} \left\{ \exp \left[ \frac{D_1 - D_2}{D_2} N_\phi \tan \phi \tan \left( \frac{\pi}{8} + \frac{\phi}{4} \right) \right] - 2N_\phi^{(1/2)} \tan \phi - 1 \right\} + \frac{2 \tan \phi + 2N_\phi^{(1/2)} + N_\phi^{-(1/2)}}{N_\phi^{(1/2)} \tan \phi + N_\phi - 1} - \right. \\ \left. - c \left( D_1 \frac{2 \tan \phi + 2N_\phi^{(1/2)} + N_\phi^{-(1/2)}}{N_\phi^{(1/2)} \tan \phi + N_\phi - 1} - 2D_2 N_\phi^{-(1/2)} \right) + \frac{\gamma Z}{N_\phi} \left\{ A \exp \left[ \frac{D_1 - D_2}{D_2} N_\phi \tan \phi \tan \left( \frac{\pi}{8} + \frac{\phi}{4} \right) \right] - D_2 \right\} \right)$$

where the constants are A which is equal to  $D1(D1/D2)^b$  with  $b=(N_{\phi}^{1/2} \tan \phi + N_{\phi} - 1)$  and  $N_{\phi} = \tan^2[\pi/4 + \phi/2]$ . The soil strength parameters are c and  $\phi$ ,  $\gamma$  is the unit weight of soil, z is the depth, and D1 and D2 are as defined in Figure 18.

An example chart is shown in Figure 19. In general, for a constant diameter of pile, the lateral force increases as the interval between piles becomes progressively narrower. This is because the soil just around the piles finds it harder to pass through the gap between them and more load is therefore transferred to the piles. On this basis the factor of safety of the slope would increase as the spacing between piles decreases and more load is taken by the piles. For the same reason, the lateral force on the piles increases as the soil strength parameters c',  $\phi'$  increase. The design approach of Ito and Matsui (1975) has been used by Popescu (1991), Cantoni et al (1989) and others, as described in Section 2, with apparent success and more recently the method has been further rationalised by Hassiotis (1997).

#### Numerical analyses

Theories representing a Winkler beam on an elastic foundation have been widely used in the design of laterally

loaded piles with empirically derived non-linear springs to represent the soil (p-y curves) or a model of the soil as a linear elastic continuum (Matlock and Reese, 1960; Broms, 1964; Poulos and Davis, 1980). However the accuracy of such solutions depends upon the characterisation of the interaction between the pile and the surrounding ground. A particularly good representation of the soil-pile interaction yields a more realistic solution. Generally the analysis of a row of piles is based on either superposing the behaviour of a number of single piles or on extrapolation of the solution to cover a row of piles using semi-empirical interaction factors. Most of these analyses also consider the soil to have a horizontal surface and make no provision for the situation where a row of piles is in a slope.

More sophisticated procedures in some cases involving finite and boundary element analysis and more complex soil models have been developed (Rowe and Poulos, 1979; Chen and Poulos, 1993). These methods tend to concentrate on the ultimate lateral resistance of the piles rather than approaching spacing design via arching theory. Chen and Poulos (1993) and Yegian and Wright (1973) both concluded that for a single row of piles in a direction

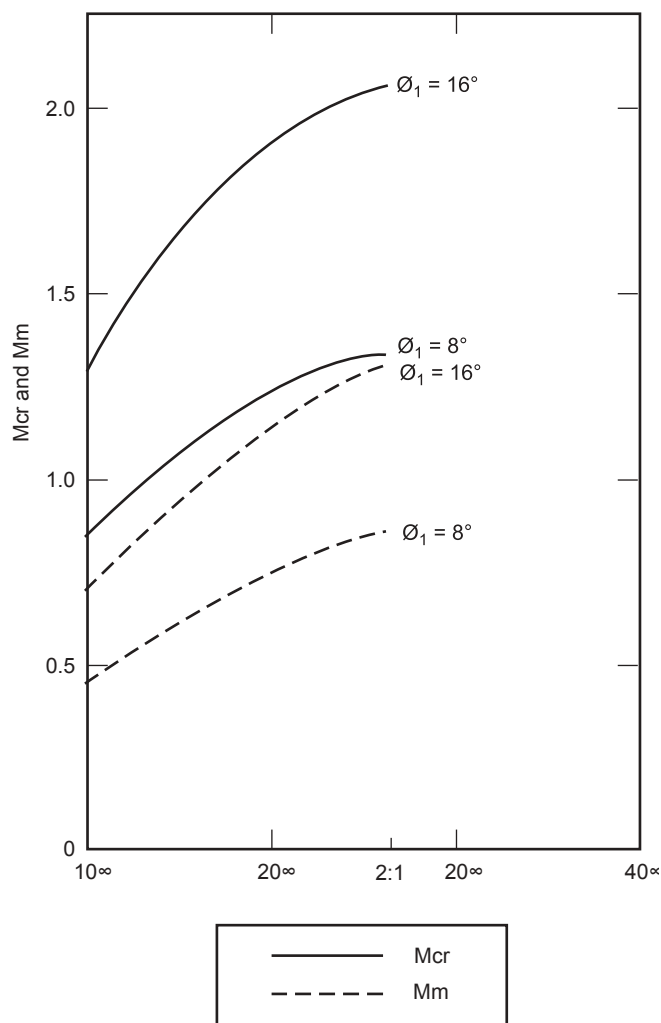

**Figure 15** Relationship between pile spacing and soil properties for 2h:1v sandy slope (After Wang and Yen, 1974) (By courtesy of ASCE)

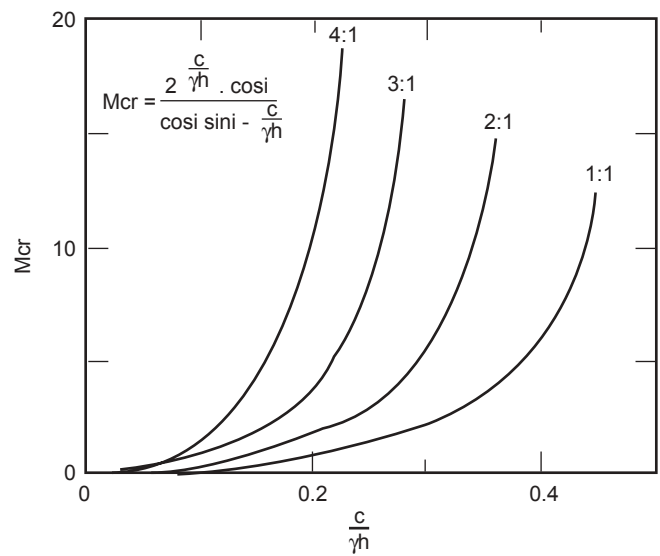

**Figure 16** Critical spacing of piles in clayey slopes ( $c'=c$ ) (After Wang and Yen, 1974)  
(By courtesy of ASCE)

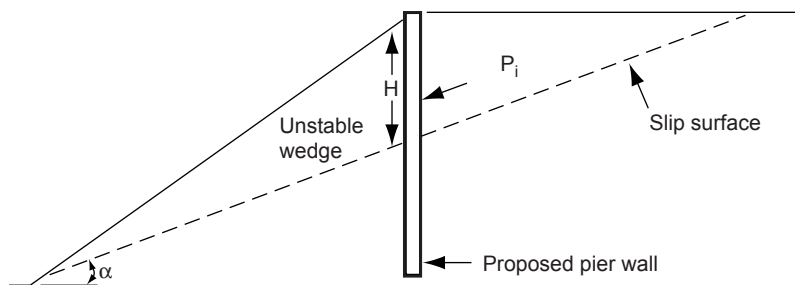

**Figure 17** Design of pier wall for wedge slope failure (After Day, 1999)  
(By courtesy of ASCE)

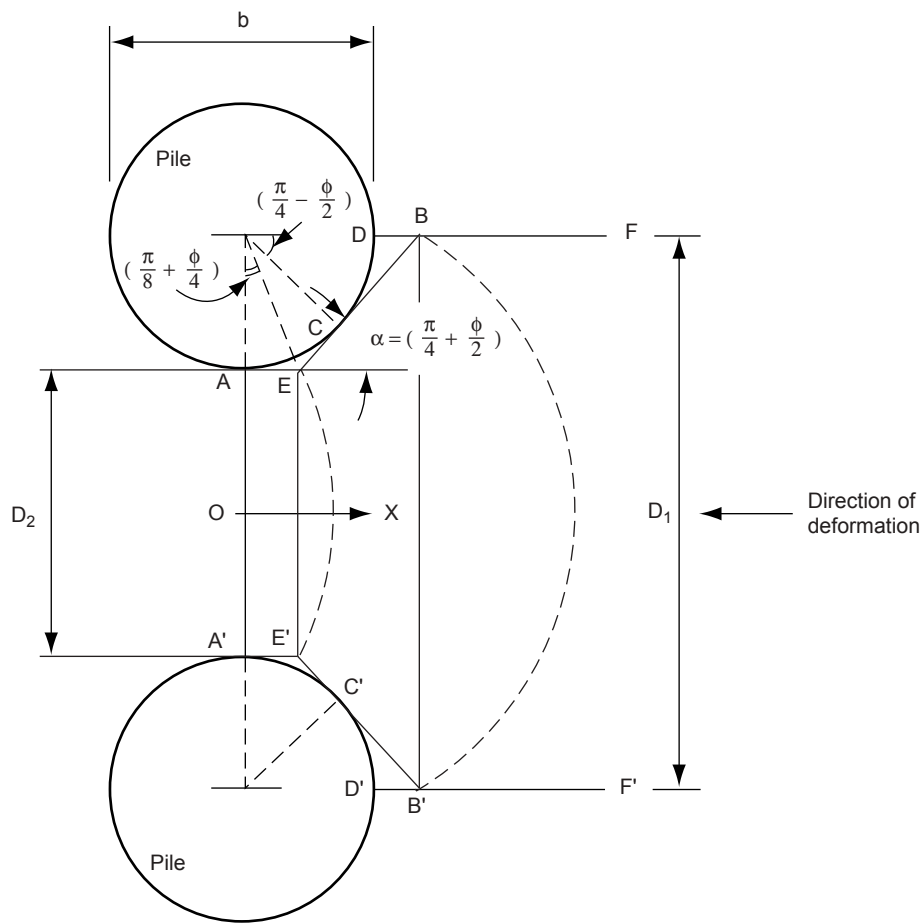

**Figure 18** Plastically deforming ground around stabilising pile (After Ito and Matsui, 1975)  
*(By courtesy of the authors)*

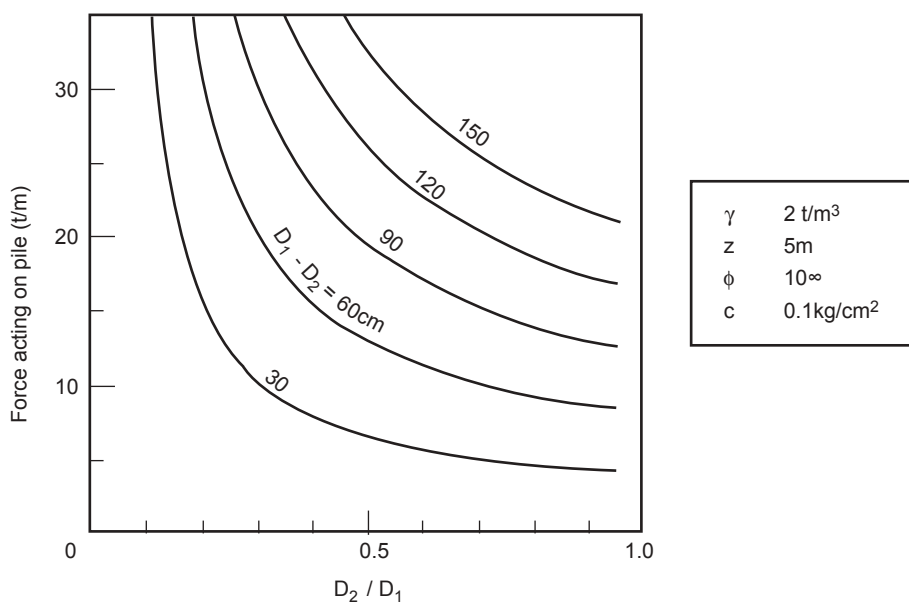

**Figure 19** Effect of pile diameter ( $D_1$ - $D_2$ ) on plastic deformation (After Ito and Matsui, 1975)  
*(By courtesy of the authors)*

perpendicular to the loading, the spacing is generally greater than 2.5 pile diameters and therefore pile interaction has only a small influence on their ultimate lateral resistance.

More complex finite element analysis involving three dimensions and a plasticity model for the soil which allows gap formation have been undertaken by Brown and Shie (1990 & 1991) and in addition to providing a better model of arching between piles, these can give a better overall view of likely performance. It is not practical to give simple rules for the evaluation of the optimum spacing between piles based on finite element analyses because of the large number of variables, although 3D models of this nature are expected to provide an effective design method.

#### 4.2 Lateral resistance supplied by the piles

Although most of the existing design approaches enable the lateral force acting on each pile to be determined, the lateral resistance supplied by the piles will be limited by the yield pressure of the soil both above and below the potential slip surface. Information on yield pressures is available for the case of laterally loaded single piles pushing through level ground and creating passive pressures.

For non-cohesive soils, Broms (1964) used a limiting soil reaction per unit length of pile of  $3K_p \sigma_v' d$  where  $d$  is the diameter of the pile. Fleming et al (1994) suggested from the data of Barton (1982) that at depths of up to 1.5 diameters, the limiting force per unit length was better given by  $K_p \sigma_v' d$ . At depths beyond this,  $K_p^2 \sigma_v' d$  was considered a better approximation. Although these formulae were derived for a pile installed in level ground, account can then be tentatively taken of the slope angle by modifying the value of  $K_p$  according to whether the resistance of the soil to the top of the pile deflecting downslope or the toe fixity of the pile is being determined.

For piles in cohesive soil, Fleming et al (1994) reports that the limiting pressure developed by level ground in front of the pile from the wedge of the soil is approximately  $2c_u$ . More complicated expressions from wedge theory have been derived by Ashour et al (1998) and for piles in sloping ground by Gabr and Borden (1990).

#### 4.3 Penetration and location of the piles

The penetration of the piles is primarily dependent upon the findings of the ground investigation. When using a row of piles to stabilise a cutting or embankment slope or to steepen a slope for highway widening purposes, the piles must extend well below the expected critical failure surface. This ensures that the failure zone does not increase to encompass the toe of the piles so obviating the potential support gained from them. The fixity of the toes of the piles is particularly important as the larger the restoring force they can sustain, the smaller will be the slope movements that occur.

Little guidance is available in the literature on the optimum location of the piles in the slope. Hassiotis et al (1997) carried out slope stability calculations for both a shallow and steep slope: their results are shown in Figure 20.

The critical surfaces of the steep slope remained deep and the factor of safety increases with  $S$  until the piles are placed close to the top of the slope. This finding should however be used with extreme caution as, if the row of piles is placed near the top of the slope, a significant failure may simply occur in front of the piles. Likewise, if the row of piles is installed near the bottom of the slope, a significant failure may occur behind the piles. Engineering judgement would suggest that the row of piles is probably better placed about one third to one half of the way up the slope, although this can be validated for a particular site situation using finite element techniques.

#### 4.4 Overall stability

##### *Conventional slope stability analyses*

The stability of the slope can be investigated by taking account of the extra restoring force provided by the piles during calculations which may be based on limit equilibrium methods such as the friction circle method and the method of slices (Bishop, 1955; Bishop and Morgenstern, 1960; Morgenstern and Price, 1967). This force can be calculated from the theory of ultimate resistance described by Poulos and Davis (1980).

Figure 21 shows an idealised section through a slope reinforced by a single row of piles where a circular failure is being assumed. Poulos and Davis give the alternative ways in which the maximum value of the restoring force can be ascertained, these are:

- i from the ultimate lateral resistance of a 'short' pile, that is the lower part of the pile ( $l_2$ );
- ii from the ultimate lateral resistance of a 'long' pile;
- iii from the ultimate load that can be developed if the soil flows between the piles over the upper part ( $l_1$ );
- iv from the shear resistance of the pile section itself.

For stability the least of the above four forces is appropriate. A sensitivity analysis of the stability of the slope following this procedure then enables decisions to be made on the pile penetration, its location on the slope, and the pile diameter. It must be noted that the critical failure surface changes when the piles are installed in the slope and for this reason an iterative procedure needs to be followed.

Viggiani (1981) studied the different failure modes that can occur and derived expressions for the maximum shear force exerted by the pile on the slip surface and of the bending moments acting on the pile. These solutions were for the ultimate limit state of purely cohesive soils and their cohesion was assumed to be constant with depth in both the unstable and stable zones. Poulos (1973 & 1975) developed a more rigorous approach with the restoring force from the piles being calculated from numerical analysis using boundary elements.

Hassiotis et al (1997), following the approach of Ito and Matsui (1975), using integration of the formula for plastic deformation of the soil between piles (see Section 4.1) to determine the ultimate load over the upper part of the piles. Their slope analyses based on determination of this force showed that, with the piles in place in both cases, the improvement in the factor of safety of the slope needed to

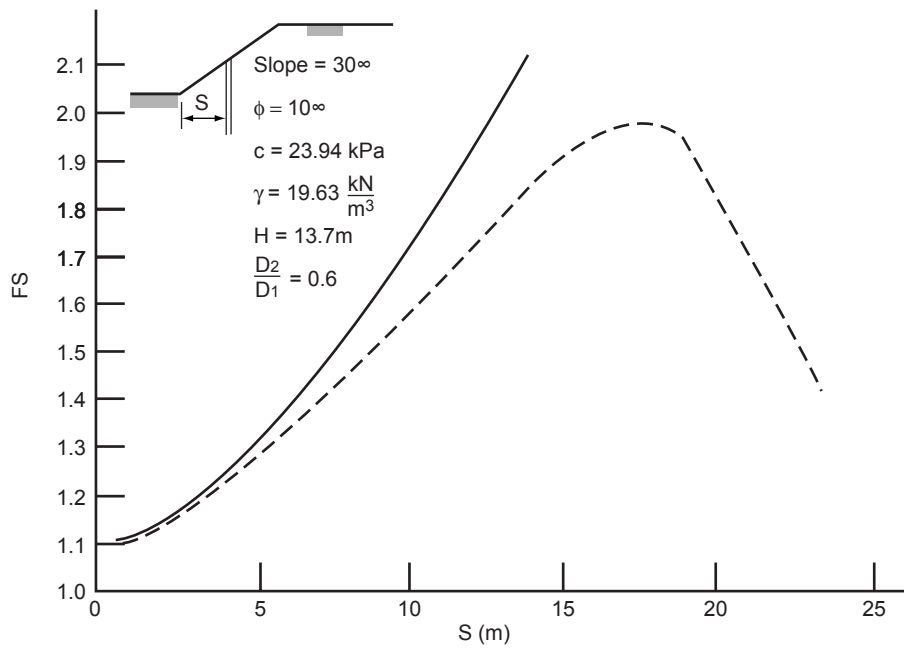

(a) Shallow slope

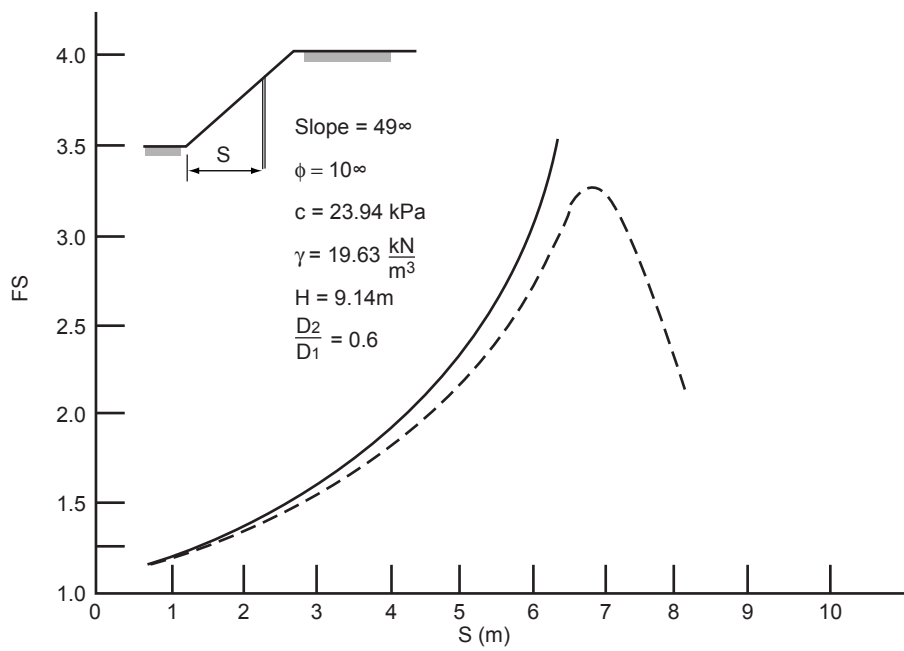

(b) Steep slope

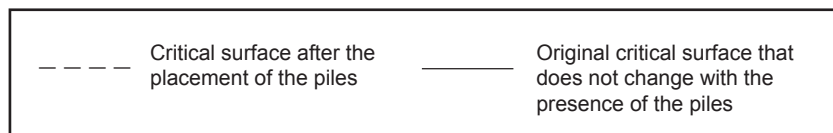

**Figure 20** Effect of pile location on factor of safety (After Hassiotis et al, 1997)  
*(By courtesy of ASCE)*

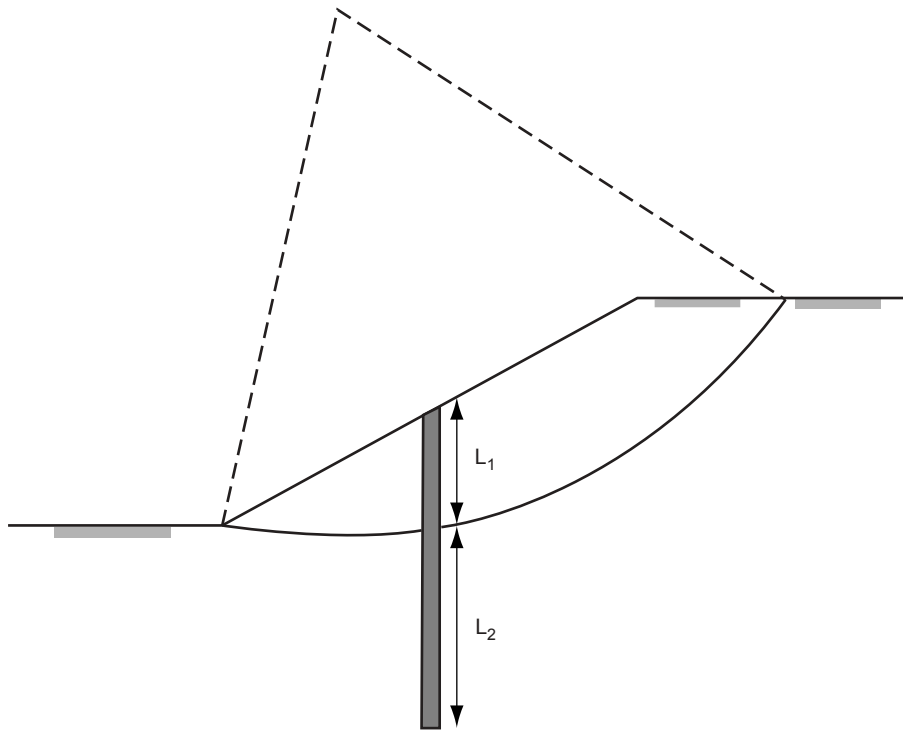

**Figure 21** Idealised section through a slope reinforced by a single row of piles

take account of the change in location of the critical failure surface from its original position (see Figure 20).

#### *Numerical analysis*

Finite element analysis has been successfully used for modelling the behaviour of slopes by many authors (Dounias et al, 1988; Bassett and Leach, 1980). If a coupled consolidation analysis is performed, the development of yielding and its location within the slope and foundation can then be predicted in the long term as excess pore water pressure dissipation occurs. Progressive failures can also be predicted if strain-softening soil models, where soil strength parameters decrease with increasing strain, are incorporated in the analysis (Potts et al, 1997).

Similarly, numerical approaches can be used in the design of a system of bored piles to stabilise a cutting or embankment slope. Crude analyses can be carried out in plane strain assuming the row of piles acts as a continuous retaining wall with stiffness reduced to reflect the soil/pile components. However in order to model more rigorously the flow or arching of soil between two adjacent piles, a three dimensional model is preferable. Because of the cost involved in modelling of this type, a more realistic approach may be to carry out the initial design using conventional slope stability analysis or 2D finite elements, followed by a more sophisticated analysis in 3D to validate the final design.

It must be noted that a variety of numerical methods using finite element, finite difference, and discrete element techniques have been successfully used to predict the development of failure in slopes.

## 5 Summary

A review of the currently available literature relevant to the use of spaced piles to stabilise embankment and cutting slopes has been undertaken and the following conclusions reached:

- i Although there is a paucity of instrumented case history studies on the use of a single row of piles to stabilise slopes, the technique appears to have been used widely and with success for some considerable time. Stabilisation of landslides and natural slopes appears to have been more frequent than attempts to stabilise embankments.
- ii Analogies have been drawn with other construction techniques where soil flow and arching occur. The principal findings from a review of the performance of piled foundations embedded in clays is that a pile spacing of about 5 times the pile diameter is sufficiently large to minimise the interaction between adjoining piles, no interaction is expected at a spacing of more than 8 diameters. On this basis it can be then argued that in a slope situation, flow of soil between piles is fairly certain at spacings of more than 8 diameters and possible at spacings of more than 5 diameters. A review of design recommendations for spill-through abutments suggested a similar result with an upper limit for spacing of 8 pier diameters (or widths) for arching to be effective in granular soils. It must be noted that some authors however recommended a lower ratio of 5 diameters.
- iii Current design approaches involve three main stages which are:
  - a evaluating the restoring shear force needed to achieve the required factor of safety for stability of the slope;

- b evaluating the shear force that each pile can provide to resist sliding;
- c selecting the diameter, spacings, penetration and most suitable location for the piles.

These stages are inter-related and, for site specific reasons, pile dimensions may well be established first. Alternative design methods for each stage are discussed in Section 4 of this report.

- iv Some of the more obvious conclusions from the review of current design methods are:
  - a the factor of safety of the slope increases as the spacing between piles decreases and more load is taken by the piles;
  - b more arching and less flow of the soil between piles occurs as the strength of the soil increases;
  - c the piles must extend well below the expected critical failure surface to ensure that the failure zone does not increase to encompass the pile toe;
  - d a single row of piles is probably better placed one third to one half of the way up the slope to avoid significant slope failures behind or in front of the piles.
- v The construction technique of using bored piles to stabilise slopes is expected to be of value in satisfying the increasing demand for embankment and cutting slopes to be steepened, so reducing the landtake and associated costs and delays to construction. The technique is also seen as a permanent structural solution in preventing or repairing slopes prone to deep seated failure and as improving the factor of safety against shallow failure. The factor of safety against shallow failure is likely to be further enhanced by the use of connecting beams or walings between the tops of adjoining piles; this technique has been used successfully outside the UK but not extensively researched.
- vi This review is part of a larger programme of research which includes centrifuge modelling, 3D finite element analyses and a full scale trial on the UK highway network. The findings from the completed research are expected to provide engineers with more detailed design guidance than is currently available.

## 6 Acknowledgements

---

The work in this report forms part of the research programme of the Structures Department at TRL. The work was funded by Quality Services (Civil Engineering) of the Highways Agency. The Project Manager for the Highways Agency was Mr R K W Lung.

The information in Appendix A was supplied by Kvaerner Construction with the kind permission of Bullen Consultants and Railtrack Project Delivery (Northwest). Likewise Appendix B was supplied by Gifford and Partners with the approval of Balfour Beatty Construction Ltd. The assistance of these various organisations was much appreciated.

## 7 References

---

**Ah-Teck C Y (1983).** *The behaviour of spill-through abutments.* MPhil Thesis, University of Cambridge.

**Allison J A, Mawditt J M and Williams G T (1991).** *The use of bored piles and counterfort drains to stabilise a major landslide - a comparison of theoretical and field performance.* Slope stability engineering, pp 369-376. Thomas Telford, London.

**Ashour M, Norris G and Pilling P (1998).** *Lateral loading of a pile in layered soil using the strain wedge model.* J Geotechnical and Geoenvironmental Engineering, ASCE, Vol 124, No 4, pp303-315.

**Bachy Limited (1996).** *Colmix brochure.* Bachy Limited, Godalming.

**Baguelin F, Frank R and Said Y H (1977).** *Theoretical study of lateral reaction mechanism of piles.* Geotechnique, Vol 27, No 3, pp405-434.

**Barker D H (1999).** *Live pole slope stabilisation in the tropics.* Manila Bioengineering Conference, April 1999.

**Barton Y O (1982).** *Laterally loaded model piles in sand.* PhD thesis, University of Cambridge.

**Bassett R H and Leach G (1980).** *A comparison of two soil models in a finite element analysis of an embankment.* Proc Symp Computer Applications to Geotechnical Problems in Highway Engineering, Cambridge, pp157-200.

**Begemann H K and De Leeuw E H (1972).** *Horizontal earth pressures on foundation piles as a result of nearby soil fills.* Proc 5<sup>th</sup> Int Conf Soil Mech Foundn Engng, Madrid, Vol 1, pp3-9.

**Bishop A W (1955).** *The use of the slip circle in the stability analysis of slopes.* Geotechnique, Vol 5, No 1, pp7-17.

**Bishop A W and Morgenstern N R (1960).** *Stability coefficients for earth slopes.* Geotechnique, Vol 10, No 4, pp129-147.

**Bourges F, Frank R and Mieussens C (1980).** *Calcul des efforts et des déplacements engendrés par des poussées latérales de sol sur les pieux.* Note Technique. Laboratoire Central Des Ponts et Chaussées, Paris.

**Blight I C (1983).** *The use of piles and ground anchors to stabilise slopes.* MSc thesis, Department of Civil Engineering, Imperial College, London.

**Brinch Hansen J (1961).** *The ultimate resistance of rigid piles against transversal forces.* Bulletin of the Danish Geotechnical Institute, No 12, pp 5-9.

- Broms B B (1964).** *Lateral resistance of piles in cohesive soils.* J Soil Mech Foundn Div, ASCE, Vol 90, No SM2, pp27-63.
- Brookes A H, West G and Carder D R (1997).** *Laboratory trial mixes for lime-stabilised soil columns and lime piles.* TRL Report TRL306. Transport Research Laboratory, Crowthorne.
- Brown D A and Shie C-F (1990).** *Three dimensional finite element model of laterally loaded piles.* Computers and Geotechnics, Vol 10, No 1, pp59-79.
- Cantoni R, Collotta T, Ghionna V N and Moretti P C (1989).** *A design method for reticulated micropile structures in sliding slopes.* Ground Engineering, Vol 22, No 4, pp 41-45.
- Carruba P, Maugeri M and Motta E (1989).** *Esperienze in vera grandezza sul comportamento do pali per la stabilizzaaione di un pendio.* Proc 17th Convegno Nazionale di Geotechnica, Vol 1, pp 81-90. Assn Geotec Italiana.
- Carter J P (1982).** *A numerical method for pile deformations due to nearby surface loads.* Proc 4<sup>th</sup> Int Conf Numerical Methods, Edmonton, Vol 2, pp811-817.
- Chen L and Poulos H G (1993).** *Analysis of pile-soil interaction under lateral loading using infinite and finite elements.* Computers and Geotechnics, Vol 15, No 4, pp189-220.
- Chen L and Poulos H G (1997).** *Piles subjected to lateral soil movements.* J Geotechnical and Geoenvironmental Engineering, ASCE, Vol 123, No 9, pp 802-811.
- Chetoe C S and Adams H C (1938).** *Reinforced concrete bridge design* (2nd Edition). Chapman and Hall, London.
- Chelapati C V (1960).** *Arching in soils due to the deflection of a rigid horizontal strip.* Proc Symp on Soil-structural Interaction, Tucson, Arizona, pp356-377.
- Day R W (1999).** *Discussion on 'Design method for stabilization of slopes with piles'.* J Geotechnical and Geoenvironmental Engng, ASCE, Vol 125, No 10, pp910-911.
- De Beer E E and Wallays M (1970).** *Stabilization of a slope in schists by means of bored piles reinforced with steel beams.* Proc 2<sup>nd</sup> Int Congress Rock Mech, Belgrade, Vol 3, pp361-369.
- De Beer E E and Wallays M (1972).** *Forces induced in piles by unsymmetrical surcharges on the soil around the piles.* Proc 5<sup>th</sup> Int Conf Soil Mech Foundn Engng, Madrid, Vol 1, pp325-332.
- Dounias G T, Potts D M and Vaughan P R (1988).** *Finite element analysis of progressive failure: two case studies.* Computers & Geotechnics, Vol 6, pp155-175.
- Engineering News Record (1977).** *Italian pile system supports slide in its first major US application.* Eng News Rec, Vol 199, No 21, p 16.
- Esu F and D'Elia B (1974).** *Interazione terreno-struttura in un palo sollecitato da una frana tipo colata.* Revista Italiana di Geotechnica, Vol 111, pp 27-38.
- Finn W D (1963).** *Boundary value problems of soil mechanics.* J Soil Mech Foundn Div, ASCE, Vol 89, No SM5, pp39-72.
- Fleming W G K, Weltman A J, Randolph M F and Elson W K (1994).** *Piling Engineering.* Blackie Group, Bishopbriggs, Glasgow.
- Fukuoka M (1977).** *The effects of horizontal loads on piles due to landslides.* Proc 9th Int Conf Soil Mech Foundn Engng, Tokyo, Speciality Session 10.
- Gabr M A and Borden R H (1990).** *Lateral analysis of piers constructed on slopes.* J Geotechnical Engineering, ASCE, Vol 116, No 12, pp1831-1850.
- Geotechnical Consulting Group (1993).** *The design of slopes for highway cuttings and embankments.* Project Report PR/CE/37/93. Transport Research Laboratory, Crowthorne. (Unpublished report available on direct application only)
- Gudehus G and Schwarz W (1985).** *Stabilisation of creeping slopes by dowels.* Proc 11th Int Conf Soil Mech Foundn Engng, San Francisco, Vol 3, pp 1697-1700.
- Hambly E C (1979).** *Bridge foundations and substructures.* Building Research Establishment. Stationery Office, London.
- Hassiotis S, Chameau J L and Gunaratne M (1997).** *Design method for stabilization of slopes with piles.* J Geotechnical and Geoenvironmental Engng, ASCE, Vol 123, No 4, pp314-323.
- Huntington W C (1957).** *Earth pressures and retaining walls.* John Wiley & Sons, London.
- Institution of Structural Engineers (1989).** *Soil-structure interaction.* Institution of Structural Engineers, London.
- Ito T and Matsui T (1975).** *Methods to estimate lateral force acting on stabilising piles.* Soils and Foundations, Vol 15, No 4, pp 43-59.
- Ito T and Matsui T (1977).** *The effects of piles in a row on the slope stability.* Proc 9th Int Conf Soil Mech Foundn Engng, Tokyo, Speciality Session 10.
- Ito T, Matsui T and Hong W P (1981).** *Design method for stabilizing piles against landslide – one row of piles.* Soils and Foundations, Vol 21, No 1, pp 21-37.

- Jaky J (1948).** *On the bearing capacity of piles.* Proc 2nd Int Conf Soil Mech Foundn Engng, Rotterdam, pp 100-103.
- Janbu N (1971).** *Slope stability computations in embankment dam engineering.* Casegrande Volume (Hosch and Poulos, eds). John Wiley and Sons, New York.
- Jenike A W (1964).** *Storage and flow of solids.* Bulletin, Vol 53, No 26. University of Utah, Salt Lake City.
- Johnson P E and Card G B (1998).** *Soil nailing for slopes.* Project Report PR/CE/74/98. Transport Research Laboratory, Crowthorne. (*Unpublished report available on direct personal application only*)
- Kalteziotis N, Zervogiannis F R, Seve G and Berche J-C (1993).** *Experimental study of landslide stabilisation by large diameter piles.* Geotechnical engineering of hard soils-soft rocks (Anagnostopoulos et al, eds), pp 1115-1124. A A Balkema, Rotterdam.
- Lee C S P (1982).** *Forces on piers in spill-through abutments.* MPhil Thesis, University of Cambridge.
- Lindsell P and Wickens H (1987).** *Long term behaviour of spill-through abutments.* Final report to TRL, Department of Civil Engineering, University of Surrey.
- Marche R (1973).** *Discussion on Speciality Session 5.* Proc 8<sup>th</sup> Int Conf Soil Mech Foundn Engng, Moscow, Vol 4, pp247-252.
- Marston A (1930).** *The theory of external loads on closed conduits in the light of the latest experiments.* Iowa Engineering Experiment Station, Bulletin 96.
- Matlock H and Reese L C (1960).** *Generalised solutions for laterally loaded piles.* J Soil Mech Foundn Div, ASCE, Vol 86, No SM5, pp 63-91.
- Morgenstern N R and Price V E (1965).** *The analysis of the stability of general slip surfaces.* Geotechnique, Vol 15, pp79-93.
- Oliver A (1995).** *Quick answer: High embankments along London Underground lines are being safeguarded using a novel application of lime stabilisation.* New Civil Engineer, 22 June, pp 18-19.
- Oteo C S (1977).** *Horizontally loaded piles – deformation influence.* Proc 9<sup>th</sup> Int Conf Soil Mech Foundn Engng, Tokyo, Speciality Session 10, pp101-106.
- Perry J (1989).** *A survey of slope condition on motorway earthworks in England and Wales.* Research Report RR199. Transport Research Laboratory, Crowthorne.
- Popescu M E (1991).** *Landslide control by means of a row of piles.* Slope stability engineering, pp 389-394. Thomas Telford, London.
- Potts D M, Kovacevic N and Vaughan P R (1997).** *Delayed collapse of cut slopes in stiff clay.* Geotechnique, Vol 47, No 5, pp953-982.
- Poulos H G (1973).** *Analysis of piles in soil undergoing lateral movement.* J Soil Mech Foundn Engng Div, ASCE, Vol 99, No SM5, pp391-406.
- Poulos H G and Davis E H (1980).** *Pile foundation analysis and design.* John Wiley & Sons, New York.
- Prakash S and Saran D (1967).** *Behaviour of laterally-loaded piles in cohesive soil.* Proc 3<sup>rd</sup> Asian Regional Conf Soil Mech Foundn Engng, Haifa, Vol 1, pp235-238.
- Randolph M F, Ah-Teck C Y and Murray R T (1985).** *Centrifuge study of spill-through abutments.* Proc 11<sup>th</sup> Int Conf Soil Mech Foundn Engng, San Francisco, Vol 2, pp1117-1120.
- Rowe R K and Poulos H G (1979).** *A method for predicting the effect of piles on slope behaviour.* Research Report No R340, University of Sydney, Australia.
- Schwarz W (1984).** *Verdübelung toniger Böden.* Veröff Inst für Bodenmech und Felsmech, Univ Karlsruhe. (In German)
- Singleton M (1996).** *Geotechnical approach to embankment maintenance.* Construction Repair, Vol 10, No 5, pp 37-8. Palladian Publications Ltd, Surrey.
- Sommer H (1977).** *Creeping slope in a stiff clay.* Proc 9<sup>th</sup> Int Conf Soil Mech Foundn Engng, Tokyo, Speciality Session 10, pp113-118.
- Spangler MG (1950).** *A theory of loads on negative projecting conduits.* Proc US Highways Research Board, 30.
- Springman S M and Bolton M D (1990).** *The effect of surcharge loading adjacent to piles.* Contractor Report CR196. Transport Research Laboratory, Crowthorne.
- Stewart D P (1992).** *Lateral loading of piles due to simulated embankment construction.* PhD Thesis, University of Cambridge.
- Stewart D P, Jewell R J and Randolph M F (1994).** *Design of piled bridge abutments on soft clay for loading from lateral soil movements.* Geotechnique, Vol 44, No 2, pp277-296.
- Swedish Geotechnical Society (1995).** *Lime and lime-cement columns: guide for project planning, construction and inspection.* SGF Report No 4:95. Swedish Geotechnical Society, Linköping.
- Terzaghi K (1936).** *Stress distribution in dry and saturated sand above a yielding trap door.* Proc 1<sup>st</sup> Int Conf Soil Mech Foundn Engng, pp307-311.

**Terzaghi K (1943).** *Theoretical soil mechanics*. John Wiley and Sons Ltd, New York.

**Viggiani C (1981).** *Ultimate lateral load on piles used to stabilise landslides*. Proc 10<sup>th</sup> Int Conf Soil Mech Foundn Engng, Stockholm, Vol 3, pp 555-560.

**Wang W L and Yen B C (1974).** *Soil arching in slopes*. J Geotechnical Engineering Division, ASCE, Vol 100, No GT1, pp 61-78.

**West G and Carder D R (1997).** *Review of lime piles and lime-stabilised soil columns*. TRL Report TRL305. Transport Research Laboratory, Crowthorne.

**Yegian M and Wright S G (1973).** *Lateral soil resistance-displacement relationships for pile foundations in soft clays*. Proc 5<sup>th</sup> Annual Offshore Tech Conf, Houston, Vol 2, pp663-676.

## Appendix A: The stabilisation of an existing railway embankment at Kitson Wood using large diameter pin-piles

### A.1 Introduction

Stabilisation of about 60m of existing railway embankment was undertaken at Kitson Wood near Todmorden in West Yorkshire. Geotechnical investigations suggested the embankment was marginally stable with evidence of incipient deep seated failure. Local excavation towards the toe of the slope along the length of the embankment may have contributed to more recent movements and caused a speed restriction to be imposed on the track.

Following further detailed geotechnical investigation, Bullen Consultants proposed a scheme of large diameter pin-piles to stabilise the deep seated slope failure. Kvaerner Construction later adopted the design, following a process of checking, under a design and build construction contract let by Railtrack Project Delivery (Northwest). In addition to the pin-piles, the stability of the embankment shoulders was also improved using a mini-piled retaining wall although this aspect is not reported here.

### A.2 Ground conditions

The ground conditions comprised ash fill to about 12m depth overlying re-worked mudstone fill which, in turn rested on weathered mudstone, probably shales of the Todmorden Grit. The pin-piles were installed through the re-worked mudstone fill into the *in-situ* mudstone, at the lower part of the slope.

### A.3 Design approach

The approach to design followed that recommended by Viggiani (1981), whereby the out-of-balance force resulting from conventional stability analysis is taken by

pin-piles to provide an adequate overall factor of safety. Final checks on the design were carried out using the procedure reported more recently by Poulos (1995).

### A.4 Final construction detail

A typical cross-section through the slope is shown in Figure A1. The final solution resulting from the detailed design was to install twenty nine, 900mm diameter continuous flight auger (CFA) piles to 15m depth. The piles were constructed in two rows 3.5m apart, and staggered at 4m centre to centre. Each pile was reinforced to full depth with a grade 50 steel universal column (356mm x 406mm x 551kg/m) encased within 30 MPa concrete. The column was installed so that its maximum bending resistance was perpendicular to the railway track.

The piles were constructed using the CFA technique whereby the pile is augered to full depth and then concreted through the hollow stem as the auger is withdrawn. The universal column is then inserted through the wet concrete to full depth.

The lower row of the pin-piles formed the foundation to a low-height retaining wall, used to assist in the final re-profiling of the embankment above the pin-piles.

### A.5 References

**Viggiani C (1981).** *Ultimate lateral load on piles used to stabilise landslides.* Proc 10<sup>th</sup> Int Conf Soil Mech Foundn Engng, Stockholm, Vol 3, pp555 - 560.

**Poulos H G (1995).** *Design of reinforcing piles to increase slope stability.* Canadian Geotechnical Journal, Vol 32, No 5, pp808 - 818.

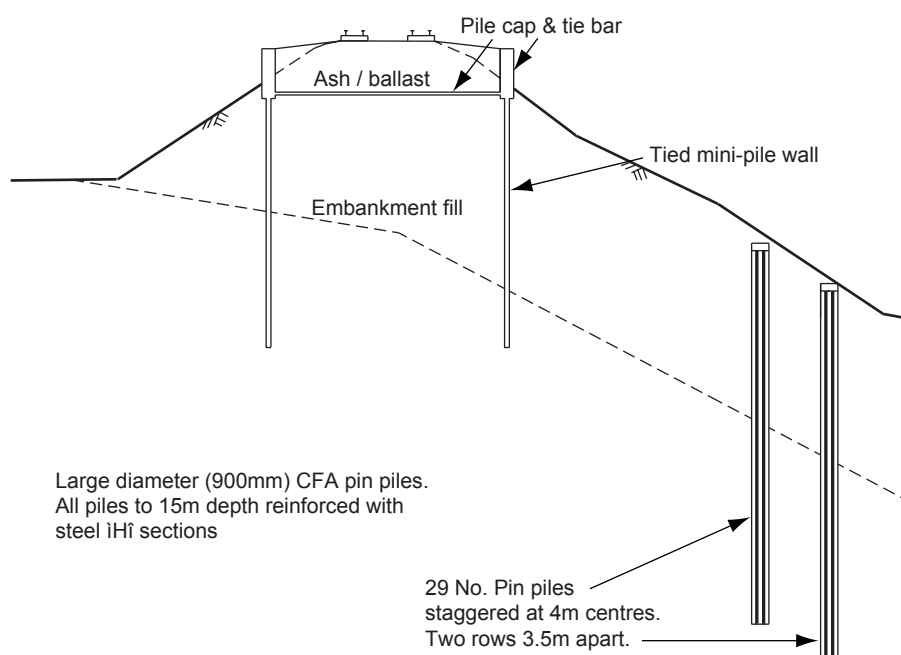

**Figure A1** Typical cross-section at Kitson Wood  
(By courtesy of Kvaerner Construction)

## Appendix B: Widening of the M25 between Junctions 8 and 10

### B.1 Introduction

The widening scheme involved the design and construction of 20 kilometres of asymmetrical widening over major earthworks mainly within London Clay or Upper Chalk; only the works involving London Clay embankments are reported here. Existing embankment side slopes had low calculated factors of safety which, in conjunction with restrictions on working space, imposed limitations on the scope of widening solutions that could be adopted. The approach finally adopted used reinforced soil to form the widening element which was placed over a single row of bored piles (Figure B1).

The contract was let as a design and build to Balfour Beatty Civil Engineering Limited with the design work being carried out by Gifford Graham and Partners.

### B.2 Geotechnical details

Widening works incorporating spaced piles with reinforced soil were used on all the embankments constructed from London Clay fill excavated from adjacent deep cuttings. Details of these embankments are given in Table B1.

**Table B1 Details of London Clay embankments**

Embankment	Side slope	Height (m)	Chainage (m)
New Barn Farm	1v: 3h	10.5	12880 – 13410
Down Wood	1v: 3h	12.0	13410 – 13800
Thornets Wood	1v: 3.5h	14.0	13800 – 14280
Mole Valley	1v: 2.5h	8.0	14610 – 16300
Woodlands Park	1v: 3h	10.0	16300 – 17000

The side slopes of the London Clay embankments are relatively steep both for the fill materials and height with a high risk of shallow side slope instability (Perry, 1989). Conventional slope stability analysis with moderately conservative effective shear strengths and measured pore pressures confirms factors of safety generally less than 1.3 and in some instances as low as 1.0.

It is also understood that the embankments were constructed very rapidly, in approximately two weeks, with very high pore pressures and some consequential failures recorded during construction. The ground investigations for the widening scheme suggested that 10 years after construction elevated pore pressures were still apparent and this, in combination with the disturbed nature of the clay, was considered the main cause of the instability.

### B.3 Design approach

The design philosophy for the spaced piles was formulated after a literature review on possible design approaches. Conventionally piles would be located where they are most effective in the toe region of an instability or potential slip mass, however for site specific reasons it was necessary to locate the piles close to the backscar of potential slip surfaces. This location does not significantly increase the factor of safety of the slope but at least ensures the stability of the widened carriageway and limits the extent of any potential deep seated failure.

For this reason, the design philosophy was to design the piles within slopes to provide adequate stability of the widening works rather than to stabilise the entire slope system. The design therefore considered the stability of the slope and pile design as separate phases. The first stage was to assess the stability of the slope using Bishop's simplified method to determine minimum required pile lengths and the risk from deep seated and shallow slip surfaces. The piles were then modelled using an elastic analysis (WALLAP) to derive bending moments and shear forces. In this analysis, the piles were treated as a continuous structure with the assumption being made that forces were transferred onto the piles by soil arching effects provided that the spacing between pile centres remained below four pile diameters. Factors of safety were determined using conventional limit equilibrium methods (CIRIA Report 104, 1984). In some cases finite element analyses (CRISP) were used to confirm the magnitude of the bending moments in the piled structure determined from the limit equilibrium analyses.

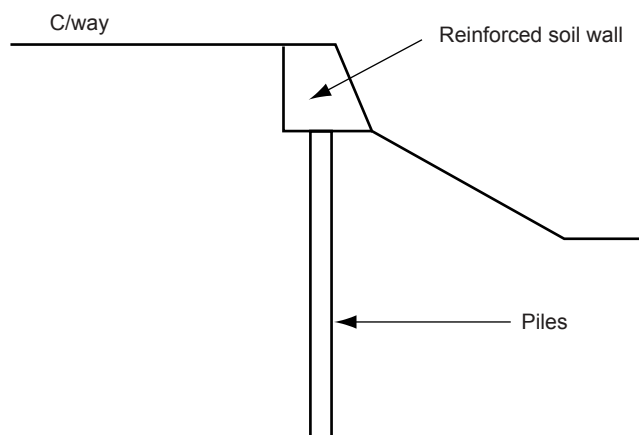

**Figure B1** Use of spaced bored piles for the M25 widening

The above design method stems from specific site constraints and would not be routinely used in all slope situations. Further details of the design method are reported by Rose al (1998).

#### **B.4 Construction detail**

Initial designs assumed 600mm diameter bored piles with the minimum length determined from stability analyses and pile spacings of 3 diameters. Typical final designs employed pile diameters ranging from 600mm to 750mm, spacings from 2.4m to 2.8m, and pile depths ranging from 6m to 14m according to the geometry and ground conditions at each particular section of slope. Generally the design aimed to achieve a minimum factor of safety of 1.5 for global stability of the widening work.

#### **B.5 References**

**Padfield C J and Mair R J (1984).** *Design of retaining walls embedded in stiff clay.* CIRIA Report 104. Construction Industry Research and Information Association, London.

**Perry J (1989).** *A survey of slope condition on motorway earthworks in England and Wales.* Research Report RR199. Transport Research Laboratory, Crowthorne.

**Rose A N, Cooper M R and Ramsey M J (1998).** *The design of spaced piles used within motorway widening work.* Report No B1124A/R01. Gifford & Partners, Southampton.

## Abstract

---

The currently available literature relevant to the use of spaced piles to stabilise embankment and cutting slopes is reviewed. The report focuses on instrumented case history studies, analogies with other construction forms where soil flow and arching occurs, and summarises the current design methods available when using this technique. The use of a single row of piles is likely to be an effective construction technique for the permanent reinstatement and repair of both unstable and failed slopes. On the highway network, many slopes which are prone to shallow failures are now reaching a critical age for deep seated failure to occur. In addition, prolonged delays in dealing with shallow failures may lead to the formation of deeper slips.

Determination of pile diameter, spacing, penetration depth and optimum location on the slope is however a complex soil-structure interaction problem on which there is currently little design guidance. This review seeks to give designers some guidance on the various issues involved.

## Related publications

---

TRL306 *Laboratory trial mixes for lime-stabilised soil columns and lime piles* by A H Brookes, G West and D R Carder. 1997 (price £25, code E)

TRL305 *Review of lime piles and lime-stabilised soil columns* by G West and D R Carder. 1997 (price £25, code E)

CR196 *The effect of surcharge loading adjacent to piles* by S M Springman and M D Bolton. 1990 (price £25, code E)

RR199 *A survey of slope condition on motorway earthworks in England and Wales* by J Perry. 1989 (price £20, code C)

Prices current at August 2000

For further details of these and all other TRL publications, telephone Publication Sales on 01344 770783 or 770784, or visit TRL on the Internet at <http://www.trl.co.uk>.